

Air-Conditioners For Building Application

HEAT SOURCE UNIT

PQHY-P-Y(S)HM-A (-BS)

CE

PQRY-P-Y(S)HM-A (-BS)

For use with R410A

INSTALLATION MANUAL

For safe and correct use, please read this installation manual thoroughly before installing the air-conditioner unit.

INSTALLATIONSHANDBUCH

Zum sicheren und ordnungsgemäßen Gebrauch der Klimageräte das Installationshandbuch gründlich durchlesen.

MANUEL D'INSTALLATION

Veillez lire le manuel d'installation en entier avant d'installer ce climatiseur pour éviter tout accident et vous assurer d'une utilisation correcte.

MANUAL DE INSTALACIÓN

Para un uso seguro y correcto, lea detalladamente este manual de instalación antes de montar la unidad de aire acondicionado.

MANUALE DI INSTALLAZIONE

Per un uso sicuro e corretto, leggere attentamente questo manuale di installazione prima di installare il condizionatore d'aria.

INSTALLATIEHANDLEIDING

Voor een veilig en juist gebruik moet u deze installatiehandleiding grondig doorlezen voordat u de airconditioner installeert.

MANUAL DE INSTALAÇÃO

Para segurança e utilização correctas, leia atentamente este manual de instalação antes de instalar a unidade de ar condicionado.

ΕΓΧΕΙΡΙΔΙΟ ΟΔΗΓΙΩΝ ΕΓΚΑΤΑΣΤΑΣΗΣ

Για ασφάλεια και σωστή χρήση, παρακαλείστε διαβάσετε προσεχτικά αυτό το εγχειρίδιο εγκατάστασης πριν αρχίσετε την εγκατάσταση της μονάδας κλιματισμού.

РУКОВОДСТВО ПО УСТАНОВКЕ

Для осторожного и правильного использования прибора необходимо тщательно ознакомиться с данным руководством по установке до выполнения установки кондиционера.

MONTAJ ELKİTABI

Emniyetli ve doğru biçimde nasıl kullanılacağını öğrenmek için lütfen klima cihazını monte etmeden önce bu elkitabını dikkatle okuyunuz.

PŘÍRUČKA K INSTALACI

V zájmu bezpečného a správného používání si před instalací klimatizační jednotky důkladně pročtěte tuto příručku k instalaci.

NÁVOD NA INŠTALÁCIU

Pre bezpečné a správne použitie si pred inštalovaním klimatizačnej jednotky, prosím, starostlivo prečítajte tento návod na inštaláciu.

TELEPÍTÉSI KÉZIKÖNYV

A biztonságos és helyes használatához, kérjük, olvassa el alaposan ezt a telepítési kézikönyvet, mielőtt telepítené a légkondicionáló egységet.

PODRĘCZNIK INSTALACJI

W celu bezpiecznego i poprawnego korzystania należy przed zainstalowaniem klimatyzatora dokładnie zapoznać się z niniejszym podręcznikiem instalacji.

PRIROČNIK ZA NAMESTITEV

Za varno in pravilno uporabo pred namestitvijo klimatske naprave skrbno preberite priročnik za namestitev.

INSTALLATIONSHANDBOK

Läs den här installationshandboken nogga innan luftkonditioneringsenheten installeras, för säker och korrekt användning.

PRIRUČNIK ZA UGRADNJU

Radi sigurne i ispravne uporabe, temeljito pročitajte ovaj priručnik prije ugradnje klimatizacijskog uređaja.

РЪКОВОДСТВО ЗА МОНТАЖ

За безопасна и правилна употреба, моля, прочетете внимателно това ръководство преди монтажа на климатизатора.

MANUAL CU INSTRUCȚIUNI DE INSTALARE

Pentru o utilizare corectă și sigură, vă rugăm să citiți cu atenție acest manual înainte de a instala unitatea de aer condiționat.

GB**D****F****E****I****NL****P****GR****RU****TR****CZ****SV****HG****PO****SL****SW****HR****BG****RO**

6

[Fig. 6.0.1]
① P200 - P300

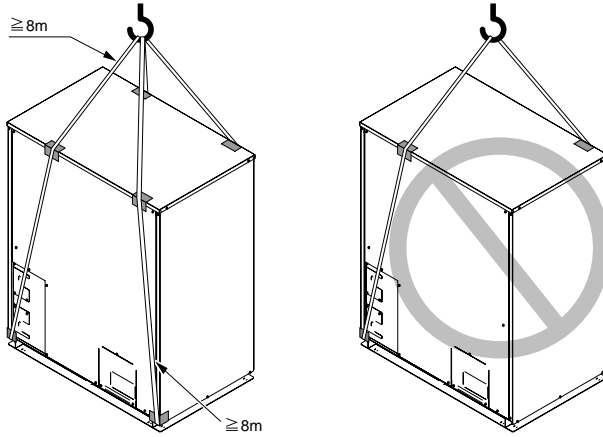

7

7.1

[Fig. 7.1.1]
<A> Without detachable leg

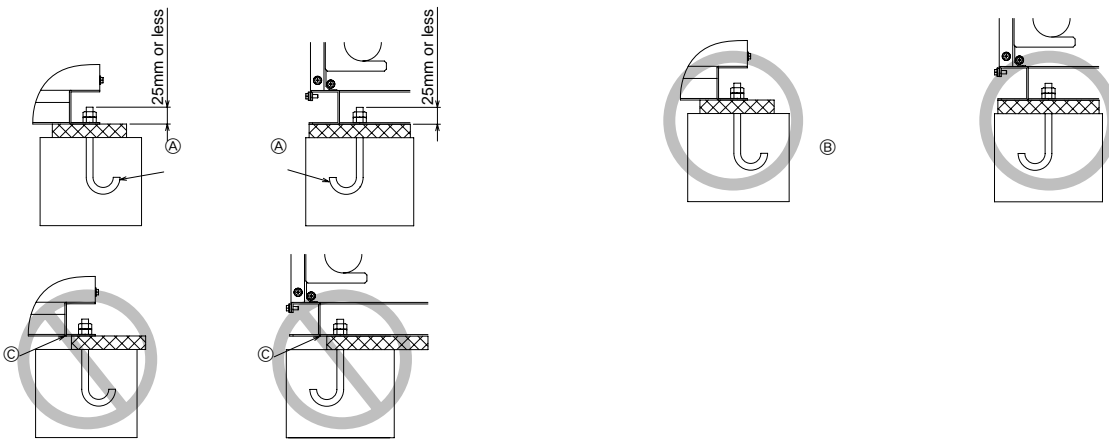

 With detachable leg

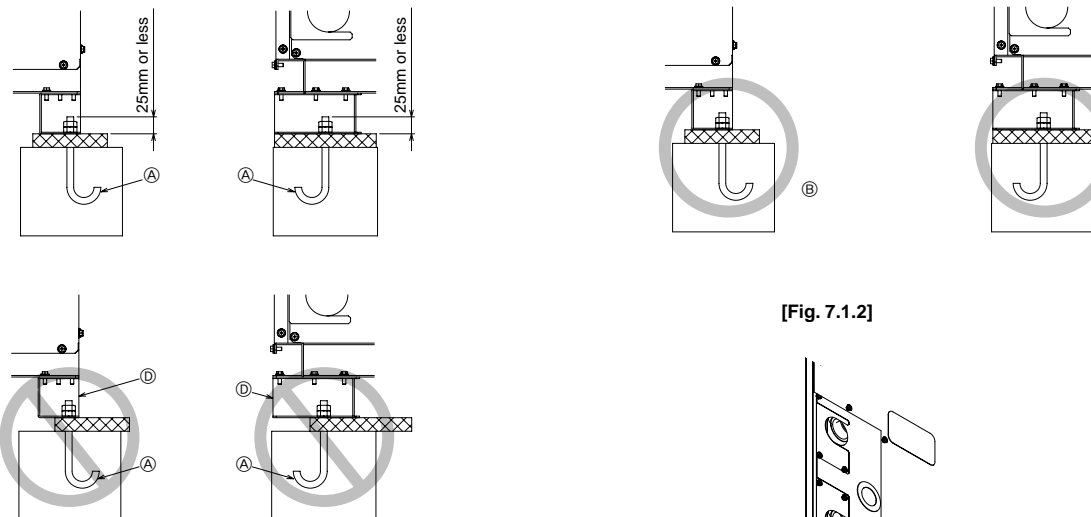

[Fig. 7.1.2]

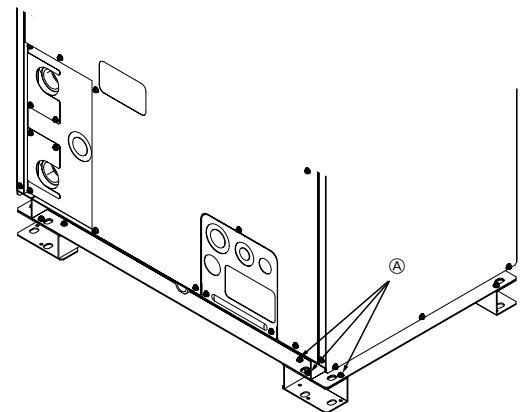

(A): Screws

- (A): M10 anchor bolt procured at the site.
- (B): Check that the corner of the installation leg is securely supported to prevent the leg from bending.
- (C): Check that the corner of the installation leg is securely supported.
- (D): Detachable leg

[Fig. 7.2.1]

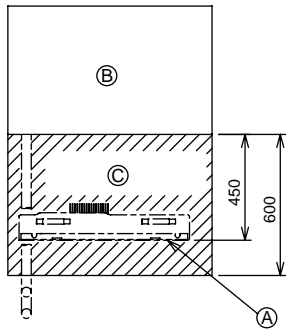

- Ⓐ: Space for removing the control box
- Ⓑ: Heat source unit
- Ⓒ: Service space (front side)

[Fig. 8.1.1]

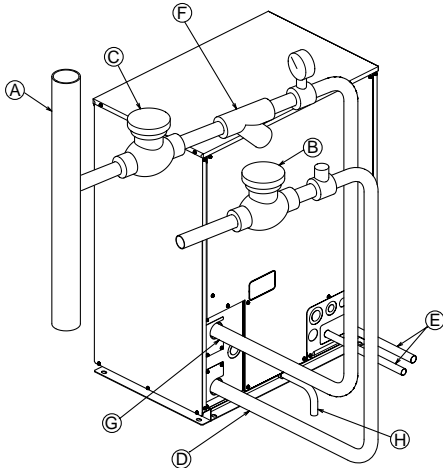

Heat source unit sample installation

- Ⓐ: Main circulating water pipe
- Ⓑ: Shutoff valve
- Ⓒ: Water inlet (upper)
- Ⓓ: Water inlet flange (upper)
- Ⓔ: Water outlet (lower)
- Ⓕ: Refrigerant pipes
- Ⓖ: Drain pipe

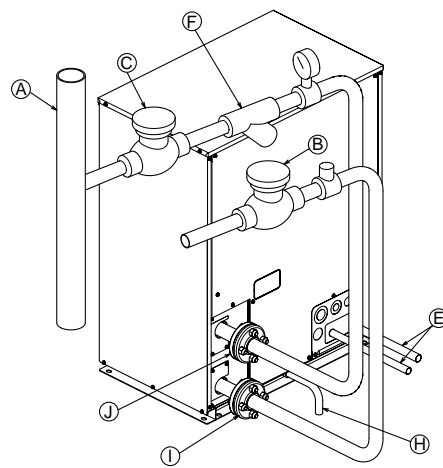

Heat source unit sample installation (high water pressure model)

- Ⓒ: Shutoff valve
- Ⓖ: Y-type strainer
- Ⓘ: Water outlet flange (lower)

[Fig. 8.4.1]



- Ⓐ: Short-circuit wire (Connected before delivery from manufacturer)
- Ⓑ: Pump interlock circuit connection

[Fig. 8.4.2]

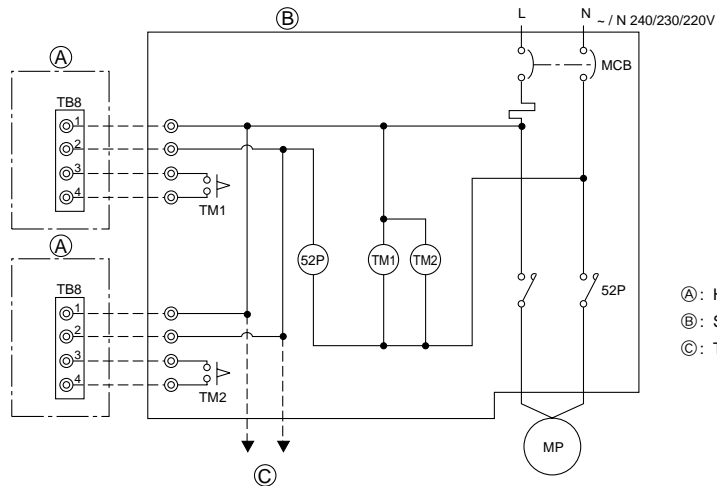

- Ⓐ: Heat source unit
- Ⓑ: Site control panel
- Ⓒ: To next unit

Terminal No.	TB8-1, 2	
Output	Relay contacts output	Rated voltage: L1-N: 220 ~ 240V Rated load: 1A
Operation	<ul style="list-style-type: none"> When Dip switch 2-7 is OFF. The relay closes during compressor operation. When DIP switch 2-7 is ON. The relay closes during reception of cooling or the heating operation signal from the controller. (Note: It is output even if the thermostat is OFF (when the compressor is stopped).) 	

[Fig. 9.2.1]

[PQHY-P200/250/300 YHM-A]

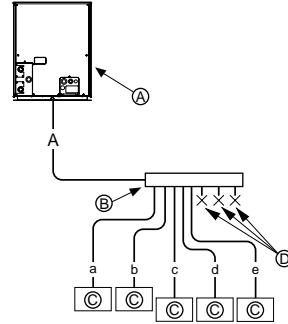
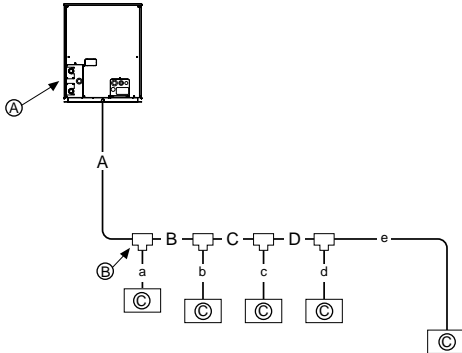

[PQHY-P400/450/500/550/600 YSHM-A]

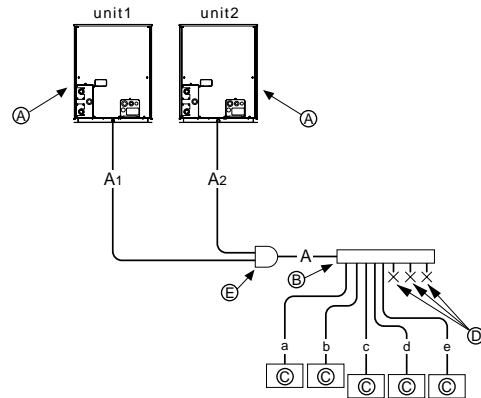
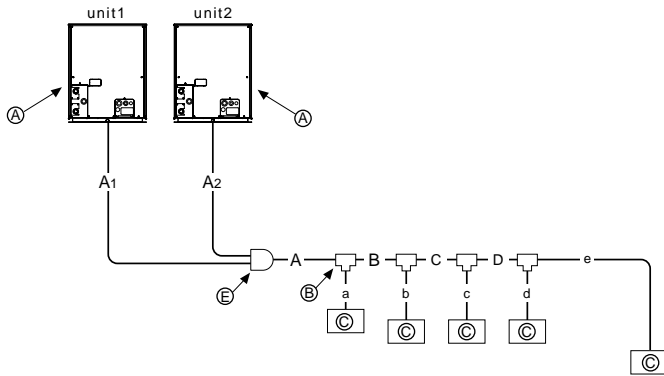

[Fig. 9.2.2]

[PQRY-P200/250/300 YHM-A]

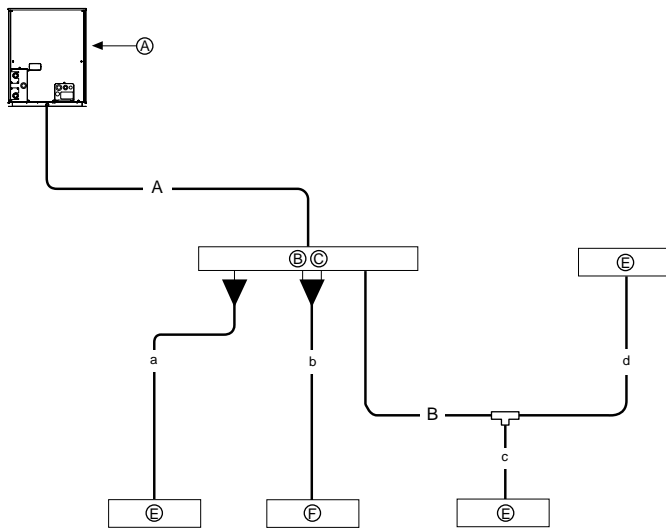

(*NOTE 1)

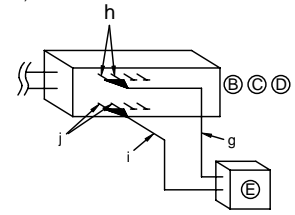

[PQRY-P400/450/500/550/600 YSHM-A]

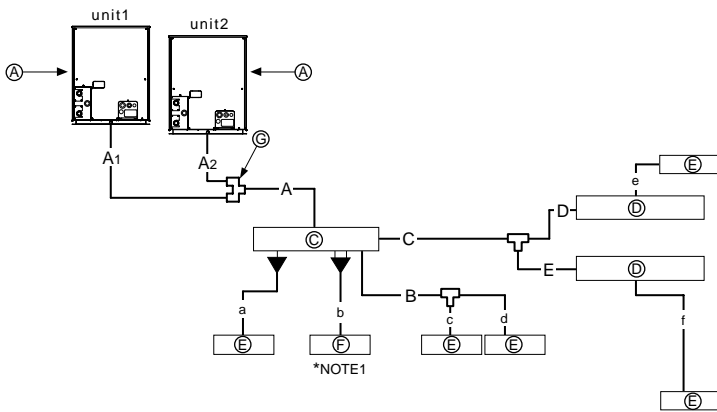

- Ⓐ : Heat source unit
- Ⓑ : BC controller (standard)
- Ⓒ : BC controller (main)
- Ⓓ : BC controller (sub)
- Ⓔ : Indoor unit (15 ~ 80)
- Ⓕ : Indoor unit (100 ~ 250)
- Ⓖ : Heat source twinning kit

PQHY-P-Y(S)HM-A

A [Standard]

(mm)

A Heat source model	Unit combination		A		A1 *1		A2 *1	
	unit 1	unit 2	B Liquid Side	C Gas Side	B Liquid Side	C Gas Side	B Liquid Side	C Gas Side
P200	-	-	ø9.52	ø19.05	-	-	-	-
P250	-	-	*1 ø9.52	ø22.2	-	-	-	-
P300	-	-	*2 ø9.52	ø22.2	-	-	-	-
P400	P200	P200	ø12.7	ø28.58	ø9.52	ø19.05	ø9.52	ø19.05
P450	P250	P200	ø15.88	ø28.58	ø9.52	ø22.2	ø9.52	ø19.05
P500	P250	P250	ø15.88	ø28.58	ø9.52	ø22.2	ø9.52	ø22.2
P550	P300	P250	ø15.88	ø28.58	ø12.7	ø22.2	ø9.52	ø22.2
P600	P300	P300	ø15.88	ø28.58	ø12.7	ø22.2	ø12.7	ø22.2

PQRY-P-Y(S)HM-A

A [Standard]

(mm)

A Heat source model	Unit combination		A		A1 *1		A2 *1	
	unit 1	unit 2	D High press.Side	E Low press.Side	D High press.Side	E Low press.Side	D High press.Side	E Low press.Side
P200	-	-	ø15.88	ø19.05	-	-	-	-
P250	-	-	ø19.05	ø22.2	-	-	-	-
P300	-	-	ø19.05	ø22.2	-	-	-	-
P400	P200	P200	ø22.2	ø28.58	ø15.88	ø19.05	ø15.88	ø19.05
P450	P250	P200	ø22.2	ø28.58	ø19.05	ø22.2	ø15.88	ø19.05
P500	P250	P250	ø22.2	ø28.58	ø19.05	ø22.2	ø19.05	ø22.2
P550	P300	P250	ø28.58	ø28.58	ø19.05	ø22.2	ø19.05	ø22.2
P600	P300	P300	ø28.58	ø28.58	ø19.05	ø22.2	ø19.05	ø22.2

*1 ø12.7 for over 90m

*2 ø12.7 for over 40m

*3 The pipe sizes listed in columns A1 to A3 in this table correspond to the sized for the models listed in the unit 1, 2, and 3 columns. When the order of the models for unit 1, 2, and 3 change, make sure to use the appropriate pipe size.

PQHY-P-Y(S)HM-A

B, C, D

(mm)

F Total capacity of indoor units	G Liquid pipe	H Gas pipe
~ 140	ø9.52	ø15.88
141 ~ 200	ø9.52	ø19.05
201 ~ 300	ø9.52	ø22.2
301 ~ 400	ø12.7	ø28.58
401 ~ 650	ø15.88	ø28.58
651 ~	ø19.05	ø34.93

a, b, c, d, e

(mm)

I Model number	B Liquid pipe	C Gas pipe
20,25,32,40,50	ø6.35	ø12.7
63,71,80,100,125,140	ø9.52	ø15.88
200	ø9.52	ø19.05
250	ø9.52	ø22.2

J Downstream unit model total	M Joint
~ 200	CMY-Y102S-G2
201 ~ 400	CMY-Y102L-G2
401 ~ 650	CMY-Y202-G2
K The 1st branch of P450 ~ P650	
651 ~	CMY-Y302-G2

A Heat source model	Q Heat source twinning kit
P400 ~ P600	CMY-Y100VBK2

N 4-Branching header (Downstream unit model total ≤ 200)	O 8-Branching header (Downstream unit model total ≤ 400)	P 10-Branching header (Downstream unit model total ≤ 650)
CMY-Y104-G	CMY-Y108-G	CMY-Y1010-G

PQRY-P-Y(S)HM-A

B

(mm)

F Total capacity of indoor units	G Liquid pipe	H Gas pipe
~ 80	ø9.52	ø15.88

C, D

(mm)

J Downstream unit model total	R High-pressure gas pipe	S Low-pressure gas pipe	G Liquid pipe
~ 200	ø15.88	ø19.05	ø9.52
201 ~ 300	ø19.05	ø22.2	ø9.52
301 ~ 350	ø19.05	ø28.58	ø12.7
351 ~ 400	ø22.2	ø28.58	ø12.7
401 ~ 450	ø22.2	ø28.58	ø15.88

g, h, i, j

(mm)

I Model number	G Liquid pipe		H Gas pipe	
	g	h	i	j
100	ø9.52	ø9.52	ø15.88	ø15.88
125	ø9.52	ø9.52	ø15.88	ø15.88
140	ø9.52	ø9.52	ø15.88	ø15.88
200	ø9.52	ø9.52	ø19.05	ø15.88
250	ø9.52	ø9.52	ø22.2	ø15.88

A Heat source model	Q Heat source twinning kit
P400 ~ P600	CMY-Q100VBK

a, b, c, d, e, f

(mm)

I Model number	G Liquid pipe	H Gas pipe
15,20,25,32,40,50	ø6.35	ø12.7
63,71,80,100,125,140	ø9.52	ø15.88
200	ø9.52	ø19.05
250	ø9.52	ø22.2

[Fig. 9.2.3]

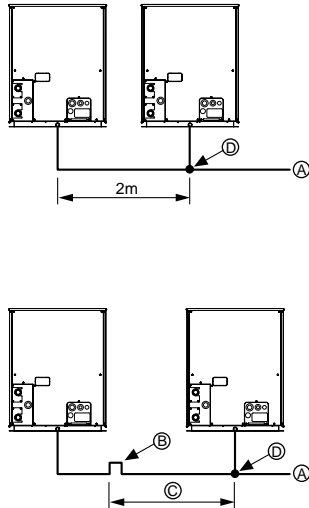

<A> When the piping on the heat source unit side (from the twinning pipe) exceeds 2 m, ensure a trap (gas pipe only) within 2 m. Make sure the height of the trap is 200 mm or more. If there is no trap, oil can accumulate inside the pipe, causing a shortage of oil and may damage the compressor. (for PQHY-P-YSHM-A)

 Pipe connection example (for PQHY-P-Y(S)HM-A)

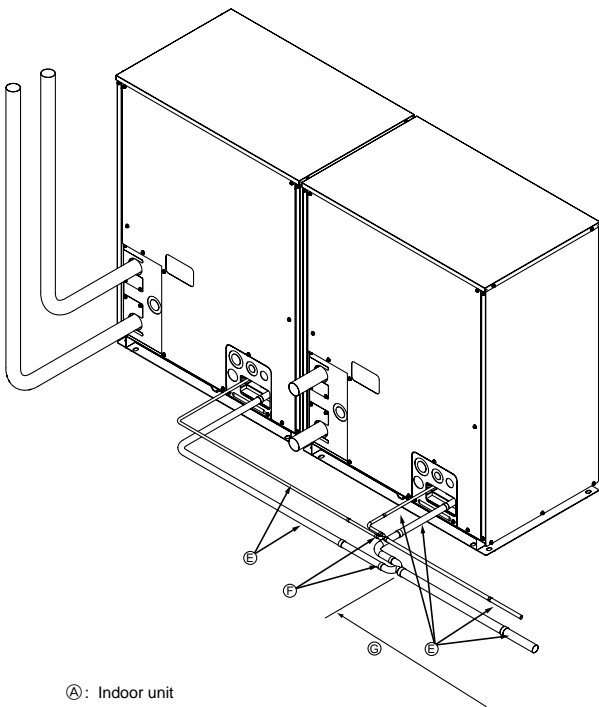

- Ⓐ: Indoor unit
- Ⓑ: Trap (gas pipe only)
- Ⓒ: Within 2 m
- Ⓓ: Twinning pipe
- Ⓔ: Pipes on site
- Ⓕ: Twinning kit
- Ⓖ: Straight run of pipe that is 500 mm or more

[Fig. 9.2.4]

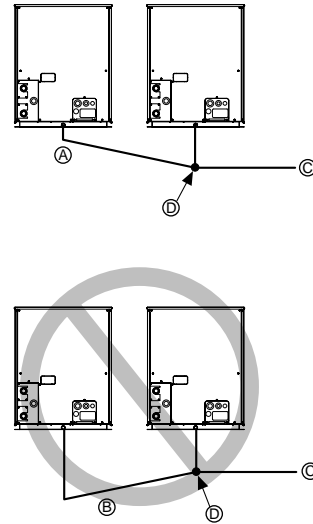

<A> The piping from the heat source units to twinning pipe must be made to slope downwards the twinning pipe. (both the liquid and the gas side for PQHY-P-YSHM-A, the high-pressure side only for PQR-Y-P-YSHM-A)

 Slope of twinning pipes (for PQHY-P-YSHM-A)
Make sure the slope of the twinning pipes are at an angle within $\pm 15^\circ$ to the horizontal plane. If the slope exceeds the specified angle, the unit may be damaged.

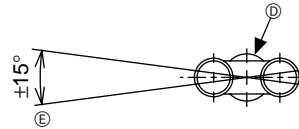

<C> Pipe connection example (for PQR-Y-P-YSHM-A)

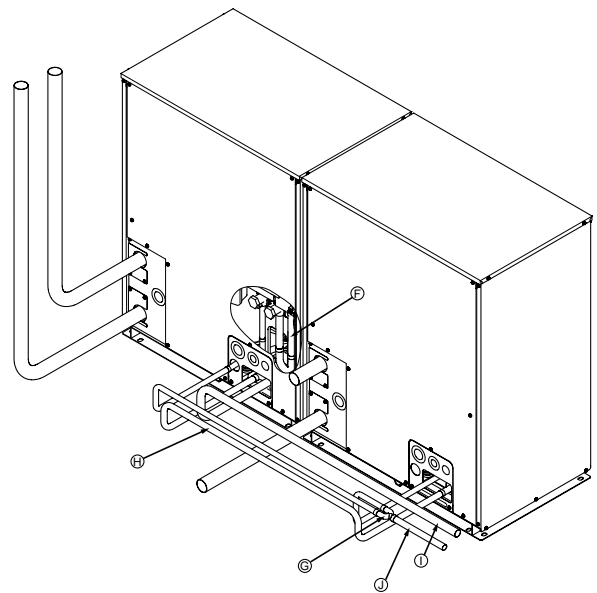

- Ⓐ: Downward slope
- Ⓑ: Upward slope
- Ⓒ: BC controller (standard or main)
- Ⓓ: Twinning pipe
- Ⓔ: Slope of the twinning pipe is at an angle within $\pm 15^\circ$ to the ground
- Ⓕ: Twinning pipe (low-pressure side)
- Ⓖ: Twinning pipe (high-pressure side)
- Ⓗ: On-site piping (low-pressure connecting pipe: between heat source units)
- Ⓖ: On-site piping (low-pressure main pipe: to BC controller)
- Ⓖ: On-site piping (high-pressure main pipe: to BC controller)

[Fig. 10.2.1]

<A> Refrigerant service valve
(Liquid side/brazed type for PQHY-P-Y(S)HM-A)
(High-pressure side/brazed type for PQRYP-P-Y(S)HM-A)

 Refrigerant service valve
(Gas side/brazed type for PQHY-P-Y(S)HM-A)
(Low-pressure side/brazed type for PQRYP-P-Y(S)HM-A)

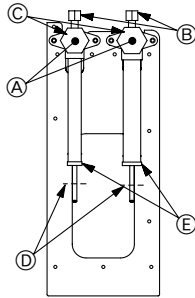

(A): Shaft
(B): Service port
(C): Cap
(D): Pinched connecting pipe severing portion
(E): Pinched connecting pipe brazing portion

[Fig. 10.2.2]

No.	①	②	③	④
(A) Shape				
PQHY-P200YHM-A	-	1 Gas side	-	1 Gas side
PQHY-P250YHM-A	-	-	1 Gas side	-
PQHY-P300YHM-A	-	-	1 Gas side	-
PQRYP-P200YHM-A	1 <C> High-pressure side	1 Low-pressure side	-	-
PQRYP-P250YHM-A	-	-	1 Low-pressure side	1 <C> High-pressure side
PQRYP-P300YHM-A	-	-	1 Low-pressure side	1 <C> High-pressure side

<A> Front pipe routing

(B) When not attaching a low-pressure twinning pipe

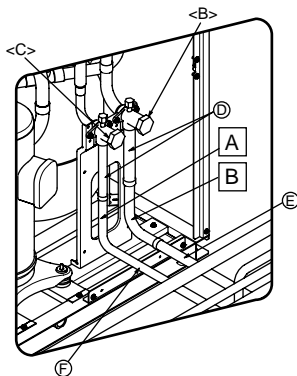

(C) When attaching a low-pressure twinning pipe (PQRYP-P-YSHM-A ONLY) *1,*2

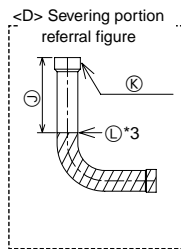
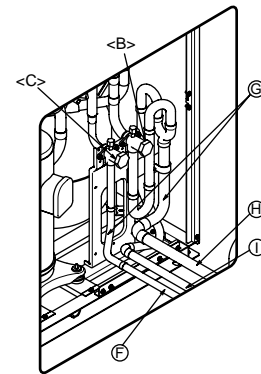

<A> Front pipe routing

<D> Severing portion referral figure

(A) Shape

(D) Refrigerant service valve piping

(E) Twinning kit (sold separately)

(H) On-site piping (low-pressure connecting pipe: to BC controller)

(I) On-site piping (low-pressure connecting pipe: to heat source unit)

(J) 75 mm (reference measurement)

 Low-pressure side PQRYP-P-Y(S)HM-A (Gas side PQHY-P-Y(S)HM-A)

(B) When not attaching a low-pressure twinning pipe

(E) On-site piping (low-pressure connecting pipe)

<C> High-pressure side PQRYP-P-Y(S)HM-A (Liquid side PQHY-P-Y(S)HM-A)

(C) When attaching a low-pressure twinning pipe (PQRYP-P-YSHM-A ONLY)

(F) On-site piping (high-pressure connecting pipe)

(L) Severing portion

*1 For the attachment of the Twinning pipe (sold separately), refer to the instructions included in the kit.

*2 Connection pipe is not used when the Twinning kit is attached.

*3 Use a pipe cutter to sever.

10.3

[Fig. 10.3.1]

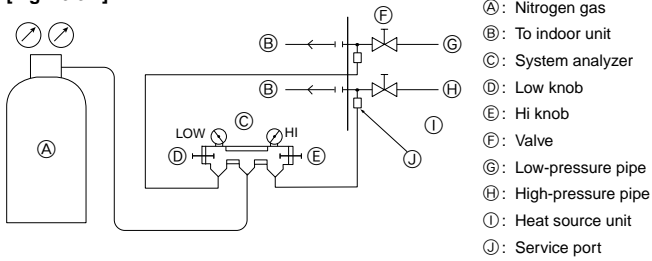

[Fig. 10.3.2]

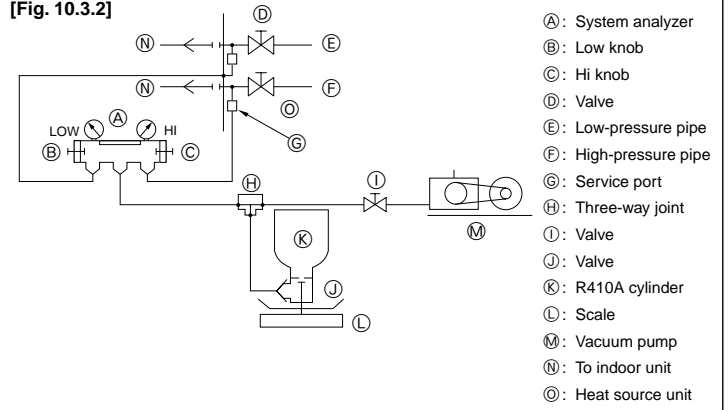

[Fig. 10.3.3]

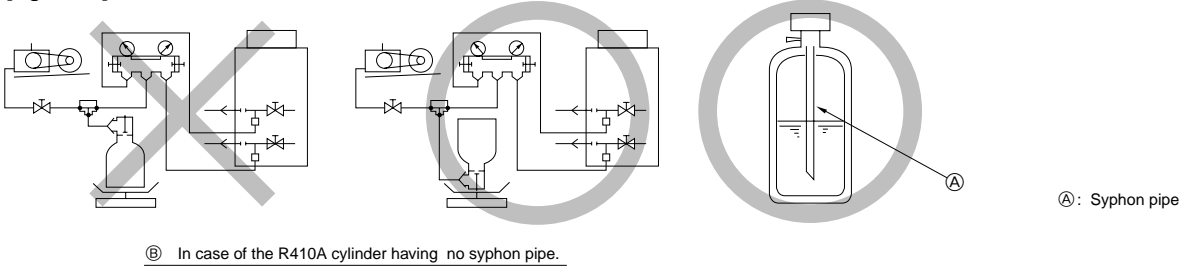

10.4

[Fig. 10.4.1]

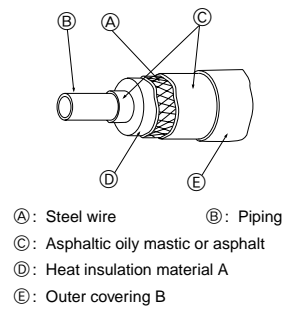

[Fig. 10.4.2]

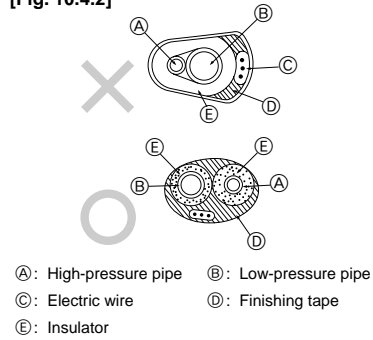

[Fig. 10.4.3]

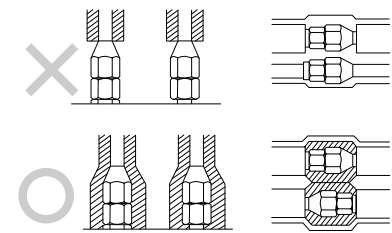

[Fig. 10.4.4]

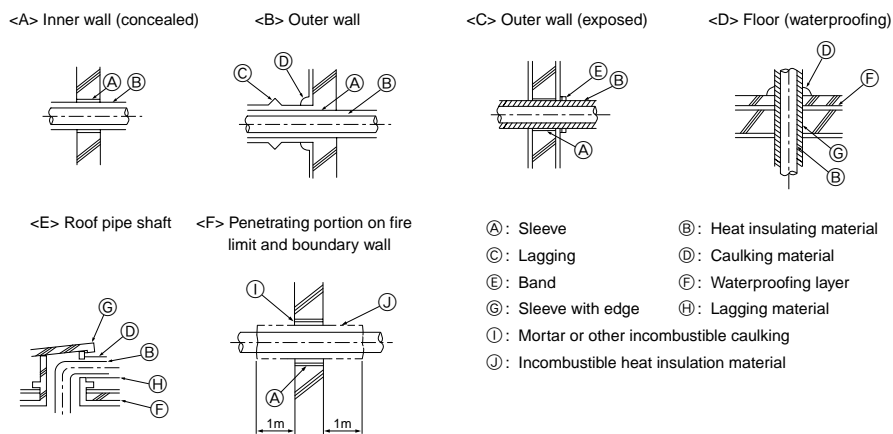

[Fig. 11.2.1]

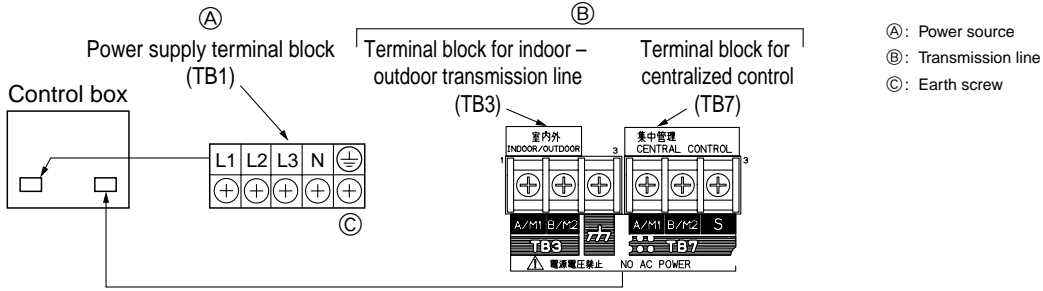

[Fig. 11.2.2]

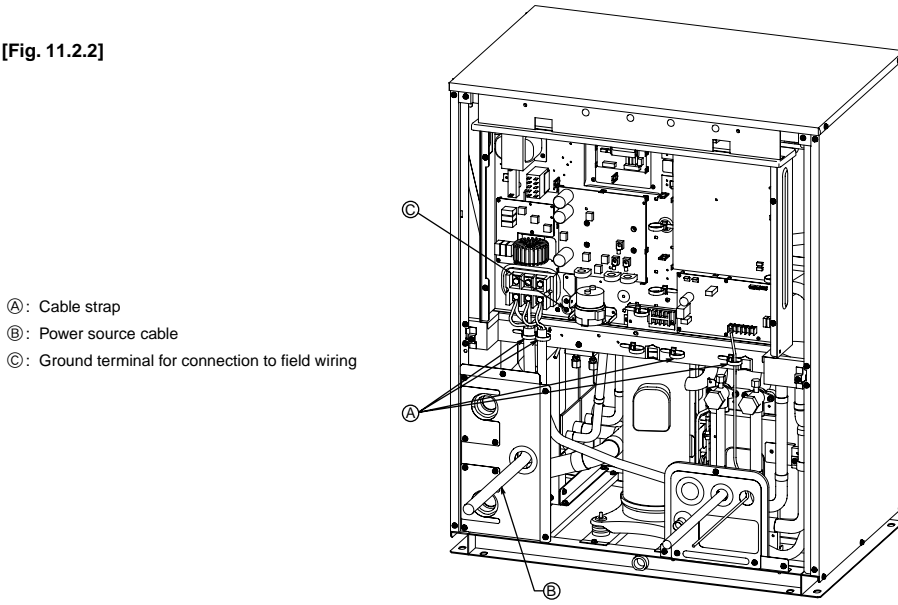

11.3

[Fig. 11.3.1]

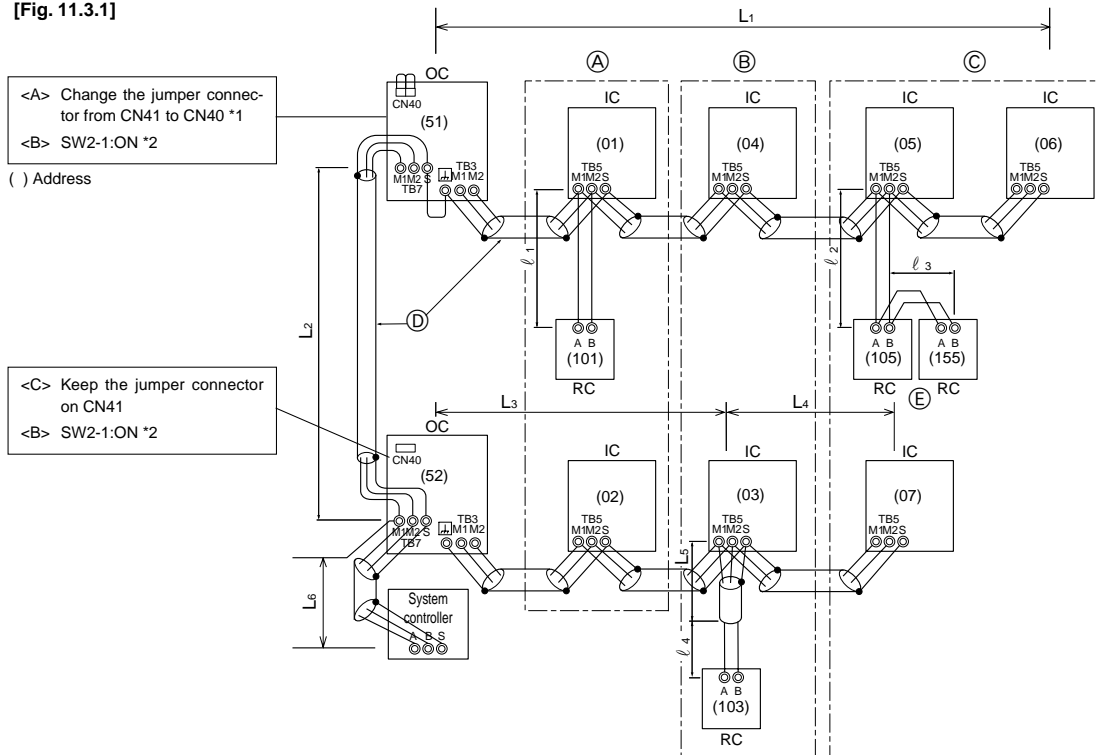

*1: When the power supply unit is not connected to the transmission line for centralized control, disconnect the male power supply connector (CN41) from ONE heat source unit in the system and connect it to CN40.

*2: If a system controller is used, set SW2-1 on all of the heat source units to ON.

[Fig. 11.3.2]

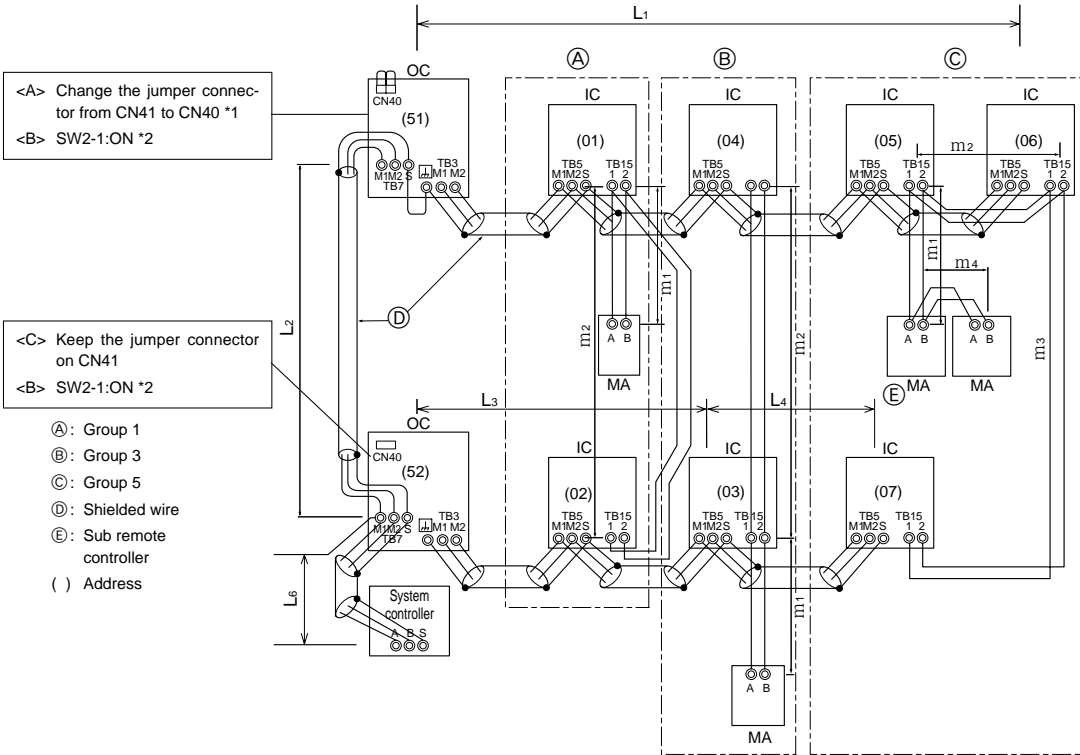

[Fig. 11.3.3]

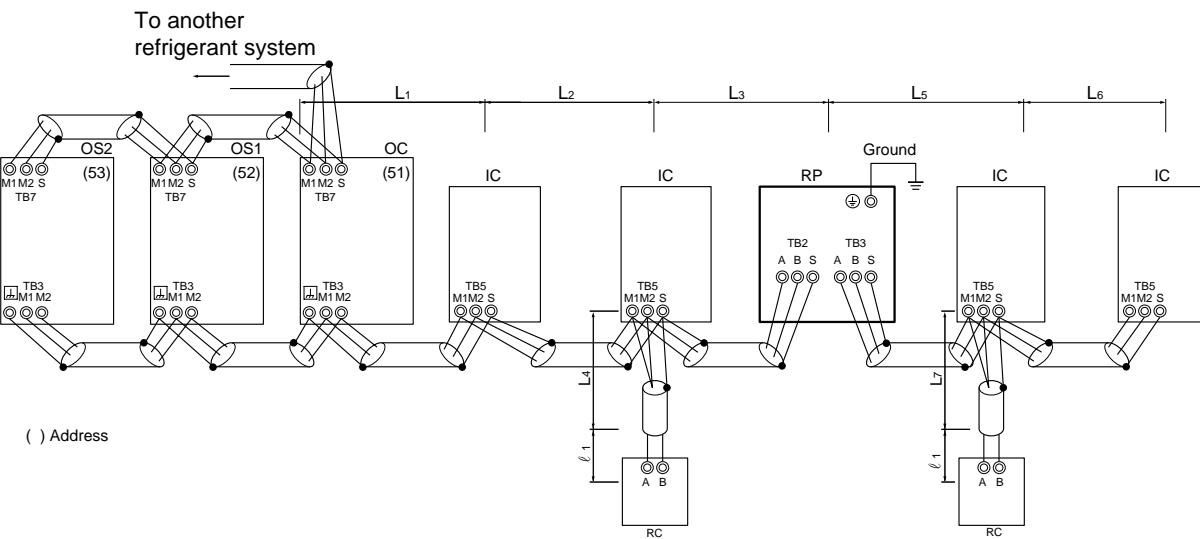

[Fig. 11.3.4]

<A> Change the jumper connector from CN41 to CN40 *1
 SW2-1:ON *2

() Address

<C> Keep the jumper connector on CN41
 SW2-1:ON *2

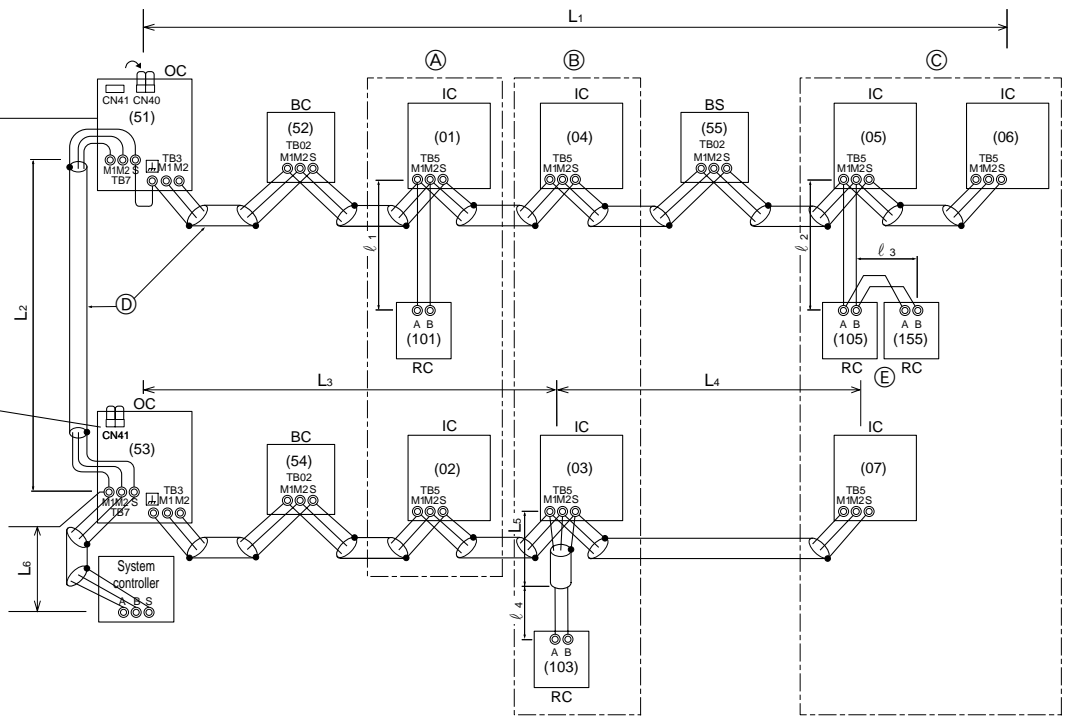

*1: When the power supply unit is not connected to the transmission line for centralized control, disconnect the male power supply connector (CN41) from ONE heat source unit in the system and connect it to CN40.

*2: If a system controller is used, set SW2-1 on all of the heat source units to ON.

[Fig. 11.3.5]

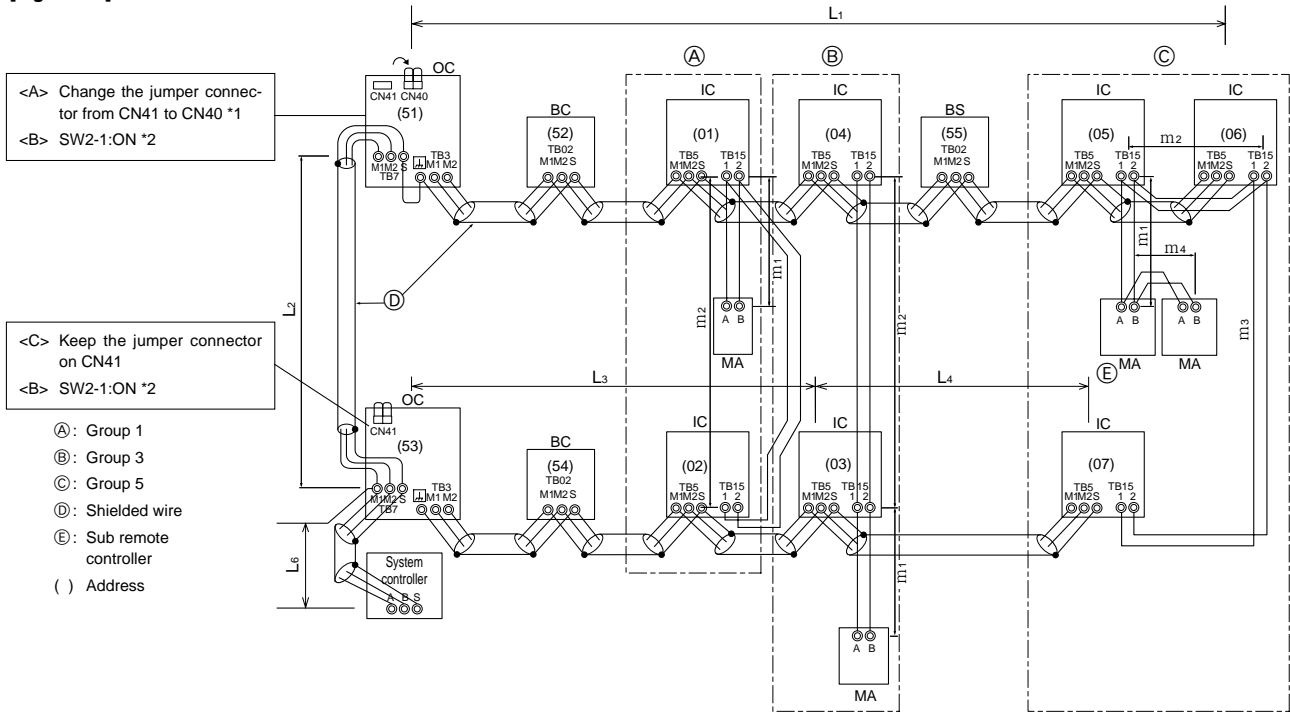

[Fig. 11.3.6]

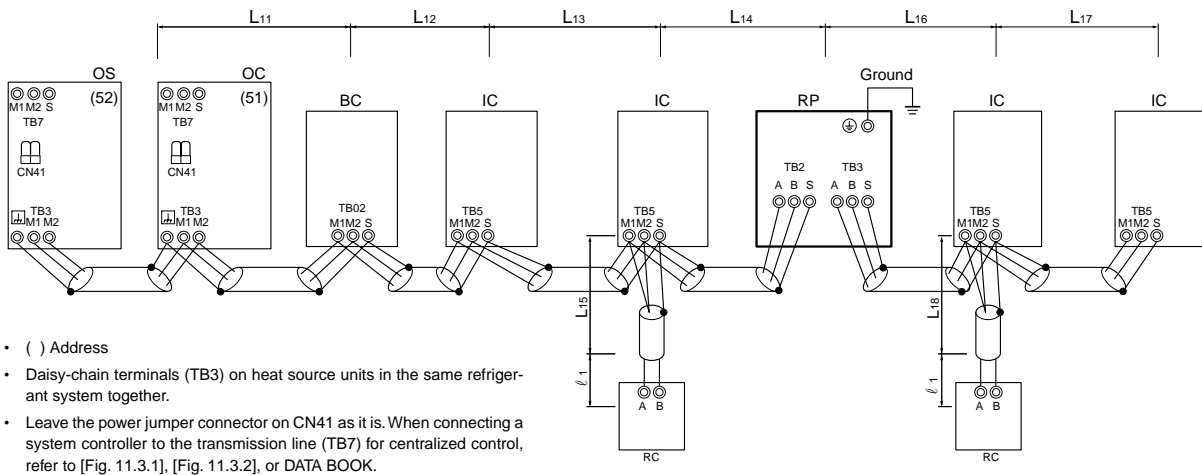

11.4

[Fig. 11.4.1]

- (A) : Switch (Breakers for wiring and current leakage)
- (B) : Breakers for current leakage
- (C) : Heat source unit
- (D) : Pull box
- (E) : Indoor unit
- (F) : BC controller (standard or main) (for PQR-Y(S)HM-A)
- (F') : BC controller (sub) (for PQR-Y(S)HM-A)

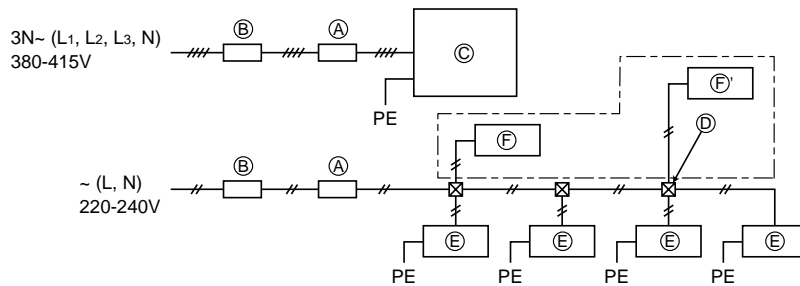



1. Safety precautions	14	9. Refrigerant piping installation.....	19
1.1. Before installation and electric work.....	14	9.1. Caution.....	19
1.2. Precautions for devices that use R410A refrigerant.....	14	9.2. Refrigerant piping system	20
1.3. Before installation.....	15	10. Additional refrigerant charge.....	21
1.4. Before installation (relocation) - electrical work.....	15	10.1. Calculation of additional refrigerant charge.....	21
1.5. Before starting the test run.....	15	10.2. Precautions concerning piping connection and valve operation	22
2. About the product.....	15	10.3. Airtight test, evacuation, and refrigerant charging.....	23
3. Combination of heat source units	16	10.4. Thermal insulation of refrigerant piping.....	24
4. Specifications.....	16	11. Wiring (For details, refer to the installation manual of each unit and controller.)	24
5. Confirmation of parts attached.....	17	11.1. Caution.....	24
6. Lifting method.....	17	11.2. Control box and connecting position of wiring.....	24
7. Installation of unit.....	17	11.3. Wiring transmission cables	25
7.1. Installation	17	11.4. Wiring of main power supply and equipment capacity	27
7.2. Service space.....	17	12. Test run	28
8. Water pipe installation.....	18	12.1. The following phenomena do not represent faults.	28
8.1. Precautions during installation	18	13. Information on rating plate	28
8.2. Insulation installation.....	18		
8.3. Water processing and water quality control	18		
8.4. Pump interlock	18		

1. Safety precautions





1.1. Before installation and electric work

- ▶ **Before installing the unit, make sure you read all the “Safety precautions”.**
- ▶ **The “Safety precautions” provide very important points regarding safety. Make sure you follow them.**

Symbols used in the text

-  **Warning:**
Describes precautions that should be observed to prevent danger of injury or death to the user.
-  **Caution:**
Describes precautions that should be observed to prevent damage to the unit.

Symbols used in the illustrations

-  : Indicates an action that must be avoided.
-  : Indicates that important instructions must be followed.
-  : Indicates a part which must be grounded.
-  : Beware of electric shock. (This symbol is displayed on the main unit label.) <Color: yellow>

-  **Warning:**
Carefully read the labels affixed to the main unit.

HIGH VOLTAGE WARNING:

- **Control box houses high-voltage parts.**
- **When opening or closing the front panel of the control box, do not let it come into contact with any of the internal components.**
- **Before inspecting the inside of the control box, turn off the power, keep the unit off for at least 10 minutes, and confirm that the voltage between FT-P and FT-N on INV Board has dropped to DC20V or less. (It takes about 10 minutes to discharge electricity after the power supply is turned off.)**

Warning:

- **The water circuit should be a closed circuit.**
- **Ask the dealer or an authorized technician to install the air conditioner.**
 - Improper installation by the user may result in water leakage, electric shock, or fire.
- **Install the unit at a place that can withstand its weight.**
 - Failure to do so may cause the unit to fall down, resulting in injuries and damage to the unit.
- **Use the specified cables for wiring. Make the connections securely so that the outside force of the cable is not applied to the terminals.**
 - Inadequate connection and fastening may generate heat and cause a fire.
- **Prepare for strong winds and earthquakes and install the unit at the specified place.**
 - Improper installation may cause the unit to topple and result in injury and damage to the unit.
- **Always use filters and other accessories specified by Mitsubishi Electric.**
 - Ask an authorized technician to install the accessories. Improper installation by the user may result in water leakage, electric shock, or fire.
- **Never repair the unit. If the air conditioner must be repaired, consult the dealer.**
 - If the unit is repaired improperly, water leakage, electric shock, or fire may result.

- **Do not touch the fan and heat exchanger fins.**
- **If refrigerant gas leaks during installation work, ventilate the room.**
 - If the refrigerant gas comes into contact with a flame, poisonous gases will be released.
- **Install the air conditioner according to this Installation Manual.**
 - If the unit is installed improperly, water leakage, electric shock, or fire may result.
- **Have all electric work done by a licensed electrician according to “Electric Facility Engineering Standard” and “Interior Wire Regulations” and the instructions given in this manual and always use a dedicated power supply.**
 - If the power source capacity is inadequate or electric work is performed improperly, electric shock and fire may result.
- **Keep the electric parts away from water (washing water etc.).**
 - It might result in electric shock, catching fire or smoke.
- **Securely install the heat source unit terminal cover (panel).**
 - If the terminal cover (panel) is not installed properly, dust or water may enter the heat source unit and fire or electric shock may result.
- **When installing and moving the air conditioner to another site, do not charge it with a refrigerant different from the refrigerant specified on the unit.**
 - If a different refrigerant or air is mixed with the original refrigerant, the refrigerant cycle may malfunction and the unit may be damaged.
- **If the air conditioner is installed in a small room, measures must be taken to prevent the refrigerant concentration from exceeding the safety limit if the refrigerant should leak.**
 - Consult the dealer regarding the appropriate measures to prevent the safety limit from being exceeded. Should the refrigerant leak and cause the safety limit to be exceeded, hazards due to lack of oxygen in the room could result.
- **When moving and reinstalling the air conditioner, consult the dealer or an authorized technician.**
 - If the air conditioner is installed improperly, water leakage, electric shock, or fire may result.
- **After completing installation work, make sure that refrigerant gas is not leaking.**
 - If the refrigerant gas leaks and is exposed to a fan heater, stove, oven, or other heat source, it may generate noxious gases.
- **Do not reconstruct or change the settings of the protection devices.**
 - If the pressure switch, thermal switch, or other protection device is shorted or operated forcibly, or parts other than those specified by Mitsubishi Electric are used, fire or explosion may result.
- **To dispose of this product, consult your dealer.**
- **The installer and system specialist shall secure safety against leakage according to local regulation or standards.**
 - Choose the appropriate wire size and the switch capacities for the main power supply described in this manual if local regulations are not available.
- **Pay special attention to the place of installation, such as a basement, etc. where refrigeration gas can accumulate, since refrigerant is heavier than the air.**

1.2. Precautions for devices that use R410A refrigerant

Caution:

- **Do not use existing refrigerant piping.**
 - The old refrigerant and refrigerant oil in the existing piping contains a large amount of chlorine which may cause the refrigerant oil of the new unit to deteriorate.
 - R410A is a high-pressure refrigerant and can cause the existing piping to burst.

- **Use refrigerant piping made of phosphorus deoxidized copper and copper alloy seamless pipes and tubes. In addition, be sure that the inner and outer surfaces of the pipes are clean and free of hazardous sulphur, oxides, dust/dirt, shaving particles, oils, moisture, or any other contaminant.**
 - Contaminants on the inside of the refrigerant piping may cause the refrigerant oil to deteriorate.
- **Store the piping to be used during installation indoors and keep both ends of the piping sealed until just before brazing. (Store elbows and other joints in a plastic bag.)**
 - If dust, dirt, or water enters the refrigerant cycle, deterioration of the oil and compressor failure may result.
- **Apply a small amount of ester oil, ether oil, or alkyl benzene to flares. (for indoor unit)**
 - Infiltration of a large amount of mineral oil may cause the refrigerant oil to deteriorate.
- **Use liquid refrigerant to fill the system.**
 - If gas refrigerant is used to fill the system, the composition of the refrigerant in the cylinder will change and performance may drop.
- **Do not use a refrigerant other than R410A.**
 - If another refrigerant (R22, etc.) is mixed with R410A, the chlorine in the refrigerant may cause the refrigerant oil to deteriorate.
- **Use a vacuum pump with a reverse flow check valve.**
 - The vacuum pump oil may flow back into the refrigerant cycle and cause the refrigerant oil to deteriorate.
- **Do not use the following tools that are used with conventional refrigerants. (Gauge manifold, charge hose, gas leak detector, reverse flow check valve, refrigerant charge base, refrigerant recovery equipment)**
 - If the conventional refrigerant and refrigerant oil are mixed in the R410A, the refrigerant may deteriorate.
 - If water is mixed in the R410A, the refrigerant oil may deteriorate.
 - Since R410A does not contain any chlorine, gas leak detectors for conventional refrigerants will not react to it.
- **Do not use a charging cylinder.**
 - Using a charging cylinder may cause the refrigerant to deteriorate.
- **Be especially careful when managing the tools.**
 - If dust, dirt, or water gets into the refrigerant cycle, the refrigerant may deteriorate.
- **Never connect in reverse phases. Never connect the Power Line L1, L2, and L3 to Terminal N.**
 - If the unit is miss wired, when power is supplied, some electrical parts will be damaged.
- **Install the power cable so that tension is not applied to the cable.**
 - Tension may cause the cable to break and generate heat and cause a fire.
- **Install a leak circuit breaker, as required.**
 - If a leak circuit breaker is not installed, electric shock may result.
- **Use power line cables of sufficient current carrying capacity and rating.**
 - Cables that are too small may leak, generate heat, and cause a fire.
- **Use only a circuit breaker and fuse of the specified capacity.**
 - A fuse or circuit breaker of a larger capacity, or the use of a substitute simple steel or copper wire may result in a general unit failure or fire.
- **Do not wash the air conditioner units.**
 - Washing them may cause an electric shock.
- **Be careful that the installation base is not damaged by long use.**
 - If the damage is left uncorrected, the unit may fall and cause personal injury or property damage.
- **Install the drain piping according to this Installation Manual to ensure proper drainage. Wrap thermal insulation around the pipes to prevent condensation.**
 - Improper drain piping may cause water leakage and damage to furniture and other possessions.
- **Be very careful about transporting the product.**
 - One person should not carry the product. Its weight is in excess of 20kg.
 - Some products use PP bands for packaging. Do not use any PP bands as a means of transportation. It is dangerous.
 - Do not touch the heat exchanger fins. Doing so may cut your fingers.
 - When transporting the heat source unit, support it at the specified positions on the unit base. Also support the heat source unit at four points so that it cannot slip sideways.
- **Safely dispose of the packing materials.**
 - Packing materials, such as nails and other metal or wooden parts, may cause stabs or other injuries.
 - Tear apart and throw away plastic packaging bags so that children will not play with them. If children play with a plastic bag which has not been torn apart, they face the risk of suffocation.

1.3. Before installation

⚠ Caution:

- **Do not install the unit where combustible gas may leak.**
 - If the gas leaks and accumulates around the unit, an explosion may result.
- **Do not use the air conditioner where food, pets, plants, precision instruments, or artwork are kept.**
 - The quality of the food, etc. may deteriorate.
- **Do not use the air conditioner in special environments.**
 - Oil, steam, sulfuric smoke, etc. can significantly reduce the performance of the air conditioner or damage its parts.
- **When installing the unit in a hospital, communication station, or similar place, provide sufficient protection against noise.**
 - Inverter equipment, private power generator, high-frequency medical equipment, or radio communication equipment may cause the air conditioner to operate erroneously, or fail to operate. On the other hand, the air conditioner may affect such equipment by creating noise that disturbs medical treatment or image broadcasting.
- **Do not install the unit on or over things that are subject to water damage.**
 - When the room humidity exceeds 80% or when the drain pipe is clogged, condensation may drip from the indoor unit. Perform collective drainage work together with the heat source unit, as required.

1.4. Before installation (relocation) - electrical work

⚠ Caution:

- **Ground the unit.**
 - Do not connect the ground wire to gas or water pipes, lightning rods, or telephone ground lines. Improper grounding may result in electric shock.

2. About the product

- This unit uses R410A-type refrigerant.
- Piping for systems using R410A may be different from that for systems using conventional refrigerant because the design pressure in systems using R410A is higher. Refer to the Data Book for more information.
- Some of the tools and equipment used for installation with systems that use other types of refrigerant cannot be used with the systems using R410A. Refer to the Data Book for more information.
- Do not use the existing piping, as it contains chlorine, which is found in conventional refrigerating machine oil and refrigerant. This chlorine will deteriorate the refrigerant machine oil in the new equipment. The existing piping must not be used as the design pressure in systems using R410A is higher than that in the systems using other types of refrigerant and the existing pipes may burst.
- **Do not vent R410A into the atmosphere.**
- **R410A is a Fluorinated Greenhouse gas, covered by the Kyoto Protocol with a Global Warming Potential (GWP) = 1975.**

⚠ Caution:

- **Do not vent R410A into the atmosphere.**
- **R410A is a Fluorinated Greenhouse gas, covered by the Kyoto Protocol with a Global Warming Potential (GWP) = 1975.**

3. Combination of heat source units

Component units of PQHY-P200 to P900 are listed below.

Heat source unit model	Component unit model	
PQHY-P200YHM-A(-BS)	-	-
PQHY-P250YHM-A(-BS)	-	-
PQHY-P300YHM-A(-BS)	-	-
PQHY-P400YSHM-A(-BS)	PQHY-P200YHM-A(-BS)	PQHY-P200YHM-A(-BS)
PQHY-P450YSHM-A(-BS)	PQHY-P250YHM-A(-BS)	PQHY-P200YHM-A(-BS)
PQHY-P500YSHM-A(-BS)	PQHY-P250YHM-A(-BS)	PQHY-P250YHM-A(-BS)
PQHY-P550YSHM-A(-BS)	PQHY-P300YHM-A(-BS)	PQHY-P250YHM-A(-BS)
PQHY-P600YSHM-A(-BS)	PQHY-P300YHM-A(-BS)	PQHY-P300YHM-A(-BS)

Component units of PQRYP200 to P600 are listed below.

Heat source unit model	Component unit model	
PQRYP200YHM-A(-BS)	-	-
PQRYP250YHM-A(-BS)	-	-
PQRYP300YHM-A(-BS)	-	-
PQRYP400YSHM-A(-BS)	PQRYP200YHM-A(-BS)	PQRYP200YHM-A(-BS)
PQRYP450YSHM-A(-BS)	PQRYP250YHM-A(-BS)	PQRYP200YHM-A(-BS)
PQRYP500YSHM-A(-BS)	PQRYP250YHM-A(-BS)	PQRYP250YHM-A(-BS)
PQRYP550YSHM-A(-BS)	PQRYP300YHM-A(-BS)	PQRYP250YHM-A(-BS)
PQRYP600YSHM-A(-BS)	PQRYP300YHM-A(-BS)	PQRYP300YHM-A(-BS)

4. Specifications

PQHY-P-YHM-A

Model	PQHY-P200YHM-A(-BS)	PQHY-P250YHM-A(-BS)	PQHY-P300YHM-A(-BS)	PQHY-P400YSHM-A(-BS)
Noise level	47dB<A>	49dB<A>	50dB<A>	50dB<A>
Net weight	195 kg	195 kg	195 kg	195 kg + 195 kg
Allowable pressure	HP:4.15 MPa, LP:2.21MPa			
Refrigerant	R410A: 5.0 kg	R410A: 5.0 kg	R410A: 5.0 kg	R410A: 5.0 kg + 5.0 kg
Indoor units	Total capacity	50 ~ 130% ^{*1}		
	Model	15 ~ 250		
	Quantity	1 ~ 17	1 ~ 21	1 ~ 26
Operation temperature	Water temperature: 10°C ~ 45°C			

Model	PQHY-P450YSHM-A(-BS)	PQHY-P500YSHM-A(-BS)	PQHY-P550YSHM-A(-BS)	PQHY-P600YSHM-A(-BS)
Noise level	51dB<A>	52dB<A>	52.5dB<A>	53dB<A>
Net weight	195 kg + 195 kg	195 kg + 195 kg	195 kg + 195 kg	195 kg + 195 kg
Allowable pressure	HP:4.15 MPa, LP:2.21MPa			
Refrigerant	R410A: 5.0 kg + 5.0 kg	R410A: 5.0 kg + 5.0 kg	R410A: 5.0 kg + 5.0 kg	R410A: 5.0 kg + 5.0 kg
Indoor units	Total capacity	50 ~ 130% ^{*1}		
	Model	15 ~ 250		
	Quantity	1 ~ 39	1 ~ 43	2 ~ 47
Operation temperature	Water temperature: 10°C ~ 45°C			

*1: The total indoor capacity of units run simultaneously is 130% or less.

PQRYP-YHM-A

Model	PQRYP200YHM-A(-BS)	PQRYP250YHM-A(-BS)	PQRYP300YHM-A(-BS)	PQRYP400YSHM-A(-BS)
Noise level	47dB<A>	49dB<A>	50dB<A>	50dB<A>
Net weight	181 kg	181 kg	181 kg	181 kg + 181 kg
Allowable pressure	HP:4.15 MPa, LP:2.21MPa			
Refrigerant	R410A: 5.0 kg	R410A: 5.0 kg	R410A: 5.0 kg	R410A: 5.0 kg + 5.0 kg
Indoor units	Total capacity	50 ~ 150% ^{*1}		
	Model	15 ~ 250		
	Quantity	1 ~ 20	1 ~ 25	1 ~ 30
Operation temperature	Water temperature: 10°C ~ 45°C			

Model	PQRYP450YSHM-A(-BS)	PQRYP500YSHM-A(-BS)	PQRYP550YSHM-A(-BS)	PQRYP600YSHM-A(-BS)
Noise level	51dB<A>	52dB<A>	52.5dB<A>	53dB<A>
Net weight	181 kg + 181 kg	181 kg + 181 kg	181 kg + 181 kg	181 kg + 181 kg
Allowable pressure	HP:4.15 MPa, LP:2.21MPa			
Refrigerant	R410A: 5.0 kg + 5.0 kg	R410A: 5.0 kg + 5.0 kg	R410A: 5.0 kg + 5.0 kg	R410A: 5.0 kg + 5.0 kg
Indoor units	Total capacity	50 ~ 150% ^{*1}		
	Model	15 ~ 250		
	Quantity	1 ~ 45	1 ~ 50 ^{*2}	2 ~ 50 ^{*2}
Operation temperature	Water temperature: 10°C ~ 45°C			

*1: The total indoor capacity of units run simultaneously is 150% or less.

*2: Connectable branch pipe number is max.48.

5. Confirmation of parts attached

- This unit includes the following parts. Please check.
- For usage methods, refer to item 10.2.

PQHY-P-YHM-A

		① Connecting pipe ID ø19.05, OD ø19.05 (ID ø3/4", OD ø3/4") <Gas side>	② Connecting pipe IDø25.4, ODø25.4 (IDø1", ODø1") <Gas side>	③ Connecting pipe ODø19.05, IDø25.4 (ODø3/4", IDø1") <Gas side>	④ Connecting pipe ODø22.2, IDø25.4 (ODø7/8", IDø1") <Gas side>	⑤ Connecting pipe IDø9.52, ODø9.52 (ODø3/8", IDø3/8") <Liquid side>	⑥ Connecting pipe IDø9.52, IDø12.7 (ODø3/8", IDø1/2") <Liquid side>	⑦ Packing (inside ø49, outside ø89)
Model	PQHY-P200YHM-A	1 pc.	–	1 pc.	–	1 pc.	–	–
	PQHY-P250YHM-A	–	1 pc.	–	1 pc.	1 pc.	1 pc.	–
	PQHY-P300YHM-A	–	1 pc.	–	1 pc.	1 pc.	1 pc.	–
	High water pressure	–	–	–	–	–	–	1 pc.

PQRY-P-YHM-A

		① Connecting pipe IDø15.88, IDø19.05 (IDø5/8", IDø3/4") <High-pressure side>	② Connecting pipe IDø19.05, IDø25.4 (IDø3/4", ODø1") <High-pressure side> <Low-pressure side>	③ Connecting pipe IDø22.2, IDø25.4 (IDø7/8", IDø1") <Low-pressure side>	④ Connecting pipe IDø19.05, ODø19.05 (IDø3/4", ODø3/4") <High-pressure side>	⑤ Packing (inside ø49, outside ø89)
Model	PQHY-P200YHM-A	1 pc.	1 pc.	–	–	–
	PQHY-P250YHM-A	–	–	1 pc.	1 pc.	–
	PQHY-P300YHM-A	–	–	1 pc.	1 pc.	–
	High water pressure	–	–	–	1 pc.	1 pc.

6. Lifting method

[Fig. 6.0.1] (P.2)

- Use suspension ropes that will withstand the weight of the unit.
- When moving the unit, use a **4-point suspension**, and avoid giving impacts to the unit (Do not use **2-point suspension**).
- Place protective pads on the unit where it comes in contact with the ropes to protect the unit from being scratched.
- Set the angle of roping at 40° or less.
- Use 2 ropes that are each longer than 8 meters.
- Place protective padding at the corners of the product to protect the product from scratches or dents that might be caused by the rope.

⚠ Caution:

Be very careful when carrying/moving the product.

- When installing the heat source unit, suspend the unit at the specified location of the unit base. Stabilize as necessary so that it does not move to the side and support it at 4 points. If the unit is installed or suspended with 3-point support, the unit may become unstable and fall.

7. Installation of unit

7.1. Installation

[Fig. 7.1.1] (P.2)

- | | |
|--|--|
| <A> Without detachable leg | With detachable leg |
| Ⓐ M10 anchor bolt procured at the site. | Ⓑ Check that the corner of the installation leg is securely supported to prevent the leg from bending. |
| Ⓒ Check that the corner of the installation leg is securely supported. | Ⓓ Detachable leg |

- Fix unit tightly with bolts so that unit will not fall down due to earthquakes or strong winds.
- Use concrete or an angle bracket for the foundation of unit.
- Vibration may be transmitted to the installation section and noise and vibration may be generated from the floor and walls, depending on the installation conditions. Therefore, provide ample vibrationproofing (cushion pads, cushion frame, etc.).
- Be sure that the corners are firmly seated. If the corners are not firmly seated, the installation feet may be bent.
- When using cushion pads, be sure that the full width of the unit is covered.
- The projecting length of the anchor bolt should be less than 25 mm.

[Fig. 7.1.2] (P.2)

- Ⓐ Screws

- The detachable leg can be removed at the site.
- Detaching the detachable leg
Loosen the three screws to detach the detachable leg (Two each in the front and back).
If the base leg finish is damaged when detaching, be sure to repair at the site.

⚠ Warning:

- **Be sure to install unit in a place strong enough to withstand its weight. Any lack of strength may cause unit to fall down, resulting in a personal injury.**
- **Have installation work in order to protect against strong winds and earthquakes. Any installation deficiency may cause unit to fall down, resulting in a personal injury.**

When building the foundation, give full attention to the floor strength, drain water disposal <during operation, drain water flows out of the unit>, and piping and wiring routes.

Precautions when routing the pipes and wires below the unit (Without detachable leg)

When routing the pipes and wires below the unit, be sure that the foundation and base work do not block the base through-holes. Also make sure the foundation is at least 100 mm high so that the piping can pass under the unit.

7.2. Service space

- Please allow for the following service spaces after installation.
- In case of single installation, 600 mm or more of back space as front space makes easier access when servicing the unit from rear side.

[Fig. 7.2.1] (P.3)

- | | |
|--------------------------------------|--------------------|
| Ⓐ Space for removing the control box | Ⓑ Heat source unit |
| Ⓒ Service space (front side) | |

8. Water pipe installation

City Multi WY/WR2 Series pipes are similar to other air-conditioning pipes, however, please observe the following precautions during installation.

8.1. Precautions during installation

- The water pressure resistance of the water pipes in the heat source unit is 1.0MPa. (2.0MPa for the high water pressure models)
- Use the reverse-return method to insure proper pipe resistance to each unit.
- Provide some joints and bulbs around inlet/outlet of each unit for easy maintenance, checkup, and replacement.
- In order to protect the heat source unit, install a strainer on the circulating water inlet pipe within 1.5 m from the heat source unit.
- Install a suitable air vent on the water pipe. After sending water through the pipe, be sure to vent the excess air.
- Compressed water may form in the low-temperature sections of heat source unit. Use a drainage pipe connected to the drain valve at the base of the unit to drain the water.
- Install a back flow-prevention valve on the pump and a flexible joint to prevent excess vibration.
- Use a sleeve to protect the pipes where they go through a wall.
- Use metal fittings to secure the pipes, and install them so that they have maximum protection against breakage and bending.
- Do not confuse the water intake and outlet valves.
- This unit doesn't have any heater to prevent freezing within tubes. When the water flow is stopped on low ambient, take out the water from tubes.
- The unused knockout holes should be closed and the opening of refrigerant pipes, water pipes, power source and transmission wires should be filled with putty and so on to prevent from rain. (field construction)
- The drain plug is installed on the unit rear at factory shipment for field-connection of the drain pipes on the front of the unit. Relocate the plug to the unit front to connect the drain pipes on the back of the unit. Check that there are no leaks from pipe connections.
- For 2-unit combination, install water pipes in parallel to each other so that the water flow rate through both units will be equal.
- Wrap the sealing tape as follows.
 - Wrap the joint with sealing tape in the direction of the threads (clockwise), and do not let the tape run over the edge.
 - Overlap the sealing tape by two-thirds to three-fourths of its width on each turn. Press the tape with your fingers so that it is pressed firmly against each thread.
 - Leave the 1.5th through 2nd farthest threads away from the pipe end unwrapped.
- Hold the pipe on the unit side in place with a spanner when installing the pipes or strainer. Tighten screws to a torque of 150 N·m.

Example of heat source unit installation (using left piping)

[Fig. 8.1.1] (P.3)

- | | |
|-------------------------------|------------------------------|
| Ⓐ Main circulating water pipe | Ⓑ Shutoff valve |
| Ⓒ Shutoff valve | Ⓓ Water outlet (lower) |
| Ⓔ Refrigerant pipes | Ⓕ Y-type strainer |
| Ⓖ Water inlet (upper) | Ⓗ Drain pipe |
| Ⓘ Water outlet flange (lower) | Ⓙ Water inlet flange (upper) |

8.2. Insulation installation

With City Multi WY/WR2 Series piping, as long as the temperature range of the circulating water is kept to average temperatures year-round (30 °C in the summer, 20 °C in the winter), there is no need to insulate or otherwise protect indoor piping from exposure. You should use insulation in the following situations:

- Any heat source piping.
- Indoor piping in cold-weather regions where frozen pipes are a problem.
- When air coming from the outside causes condensation to form on piping.
- Any drainage piping.

8.3. Water processing and water quality control

To preserve water quality, use the closed type of cooling tower for WY/WR2. When the circulating water quality is poor, the water heat exchanger can develop scales, leading to a reduction in heat-exchange power and possible corrosion of the heat exchanger. Please pay careful attention to water processing and water quality control when installing the water circulation system.

- Removal of foreign objects or impurities within the pipes. During installation, be careful that foreign objects, such as welding fragments, sealant particles, or rust, do not enter the pipes.
- Water Quality Processing
 - Depending on the quality of the cold-temperature water used in the air conditioner, the copper piping of the heat exchanger may become corroded. We recommend regular water quality processing. Cold water circulation systems using open heat storage tanks are particularly prone to corrosion. When using an open-type heat storage tank, install a water-to-water heat exchanger, and use a closed-loop circuit on the air conditioner side. If a water supply tank is installed, keep contact with air to a minimum, and keep the level of dissolved oxygen in the water no higher than 1mg/l.

② Water quality standard

Items	Lower mid-range temperature water system		Tendency		
	Recirculating water [20<T<60°C] [68<T<140°F]	Make-up water	Corrosive	Scale-forming	
Standard items	pH (25°C) [77°F]	7.0 ~ 8.0	7.0 ~ 8.0	○	○
	Electric conductivity (mS/m) (25°C) [77°F] (μs/cm) (25°C) [77°F]	30 or less [300 or less]	30 or less [300 or less]	○	○
	Chloride ion (mg Cl/l)	50 or less	50 or less	○	
	Sulfate ion (mg SO ₄ ²⁻ /l)	50 or less	50 or less	○	
	Acid consumption (pH4.8) (mg CaCO ₃ /l)	50 or less	50 or less		○
	Total hardness (mg CaCO ₃ /l)	70 or less	70 or less		○
	Calcium hardness (mg CaCO ₃ /l)	50 or less	50 or less		○
Reference items	Ionic silica (mg SiO ₂ /l)	30 or less	30 or less		○
	Iron (mg Fe/l)	1.0 or less	0.3 or less	○	○
	Copper (mg Cu/l)	1.0 or less	0.1 or less	○	
	Sulfide ion (mg S ²⁻ /l)	not to be detected	not to be detected	○	
	Ammonium ion (mg NH ₄ ⁺ /l)	0.3 or less	0.1 or less	○	
	Residual chlorine (mg Cl/l)	0.25 or less	0.3 or less	○	
	Free carbon dioxide (mg CO ₂ /l)	0.4 or less	4.0 or less	○	
Ryzner stability index	6.0 ~ 7.0	-	○	○	

Reference : Guideline of Water Quality for Refrigeration and Air Conditioning Equipment. (JRA GL02E-1994)

- Please consult with a water quality control specialist about water quality control methods and water quality calculations before using anti-corrosive solutions for water quality management.
- When replacing a previously installed air conditioning device (even when only the heat exchanger is being replaced), first conduct a water quality analysis and check for possible corrosion. Corrosion can occur in cold-water systems even if there has been no prior signs of corrosion. If the water quality level has dropped, please adjust water quality sufficiently before replacing the unit.

8.4. Pump interlock

The heat source unit may become damaged if it is operated with no water circulating through the pipes.

Be sure to interlock unit operation and the water-circuit pump. Use the terminal blocks for interlocking (TB8-1, 2, 3, 4) that can be found on the unit. In the case of a pump interlock circuit signal connection to the TB8-3, 4, remove the short-circuit wire. Also, use pressure valve 63PW with a minimum current of 5mA or less to prevent miss detection due to poor connection. Pump interlock cords of parts of appliances for heat source use shall not be lighter than polychloroprene sheathed flexible cord (design 245 IEC 57).

[Fig. 8.4.1] (P.3)

- | |
|--|
| Ⓐ Short-circuit wire (Connected before delivery from manufacturer) |
| Ⓑ Pump interlock circuit connection |

[Fig. 8.4.2] (P.3)

This circuit is for interlocking of the heat source unit operation and the water-circuit pump.

- | | |
|--------------------|----------------------|
| Ⓐ Heat source unit | Ⓑ Site control panel |
| Ⓒ To next unit | |

TM1, 2 : Timer relay (closes after elapsing the set time when it is powered, while opens promptly when it is not powered)

52P : Magnetic contactor for water circuit pump

MP : Water circuit pump

MCB : Circuit breaker

* Remove the short circuit wire between 3 and 4 when wiring to TB8.

9. Refrigerant piping installation

The pipe is connected via a terminal-branch type connection in which refrigerant piping from the heat source unit is branched at the terminal and is connected to each of the indoor units.

The method of pipe connection is as follows: flare connection for the indoor units, Gas (low-pressure for PQRYP-Y(S)HM-A) pipes and Liquid (high-pressure for PQRYP-Y(S)HM-A) pipes for heat source, brazed connection. Note that the branched sections are brazed.

Warning:

Always use extreme care to prevent the refrigerant gas from leaking while using fire or flame. If the refrigerant gas comes in to contact with a flame from any source, such as a gas stove, it breaks down and generates a poisonous gas which can cause gas poisoning. Never weld in an unventilated room. Always conduct an inspection for gas leakage after installation of the refrigerant piping has been completed.

Caution:

- Do not vent R410A into the atmosphere.
- R410A is a Fluorinated Greenhouse gas, covered by the Kyoto Protocol with a Global Warming Potential (GWP) = 1975.

9.1. Caution

This unit uses refrigerant R410A. Follow the local regulations on materials and pipe thickness when selecting pipes. (Refer to the table below.)

- Use the following materials for refrigeration piping.
 - Material: Use copper alloy seamless pipes made of phosphorus deoxidized copper. Ensure the inner and outer surfaces of the pipes are clean and free from hazardous sulfur, oxide, dusts, shaving particles, oils, and moisture (contamination).
 - Size: Refer to item 9.2. for detailed information on refrigerant piping system.
- Commercially available piping often contains dust and other materials. Always blow it clean with a dry inert gas.
- Use care to prevent dust, water or other contaminants from entering the piping during installation.
- Reduce the number of bending portions as much as possible, and make bending radii as big as possible.
- For indoor and heat source branching and merging section, be sure to use the following twinning pipe sets and merge pipe sets (sold separately).

Indoor twinning pipe kit model PQRYP-Y(S)HM-A ONLY	Indoor junction pipe kit model PQRYP-Y(S)HM-A ONLY	Heat source twinning kit model PQRYP-Y(S)HM-A ONLY
Line branch		
Lower stream unit model Less than 80 in total	Total indoor model P100 ~ P250	Total heat source model P400 ~ P600
CMY-Y102S-G2	CMY-R160-J	CMY-Q100VBK

Copper pipe size and radial thickness for R410A CITY MULTI.

Size (mm)	Size (inch)	Radial thickness (mm)	Pipe type
ø6.35	ø1/4	0.8	Type-O
ø9.52	ø3/8	0.8	Type-O
ø12.7	ø1/2	0.8	Type-O
ø15.88	ø5/8	1.0	Type-O
*ø19.05	ø3/4	1.2	Type-O
*ø19.05	ø3/4	1.0	Type-1/2H or H
ø22.2	ø7/8	1.0	Type-1/2H or H
ø25.4	ø1	1.0	Type-1/2H or H
ø28.58	ø1-1/8	1.0	Type-1/2H or H
ø31.75	ø1-1/4	1.1	Type-1/2H or H
ø34.93	ø1-3/8	1.2	Type-1/2H or H
ø41.28	ø1-5/8	1.4	Type-1/2H or H

* Both pipe types can be used for pipe size ø19.05 (3/4 inch) for R410A air conditioner.

- Use a fitting if a specified refrigerant pipe has a different diameter from that of a branching pipe.
- Always observe the restrictions on the refrigerant piping (such as rated length, height difference, and piping diameter) to prevent equipment failure or a decline in heating/cooling performance.

Indoor twinning pipe set model PQRYP-Y(S)HM-A ONLY			
Line branch			
Lower stream unit model Less than 200 in total	Lower stream unit model More than 201 and less than 400 in total	Lower stream unit model More than 401 and less than 650 in total	Lower stream unit model More than 651 in total
CMY-Y102S-G2	CMY-Y102L-G2	CMY-Y202-G2	CMY-Y302-G2

Indoor twinning pipe set model PQRYP-Y(S)HM-A ONLY		
Header branch		
4 branching	8 branching	10 branching
CMY-Y104-G	CMY-Y108-G	CMY-Y1010-G

Heat source twinning kit model PQRYP-Y(S)HM-A ONLY	
Total heat source model	
P400 ~ P600	
CMY-Y100VBK2	

- Branching cannot be made after header branching (corresponding parts are marked with X in the diagram below). *PQRYP-Y(S)HM-A ONLY.

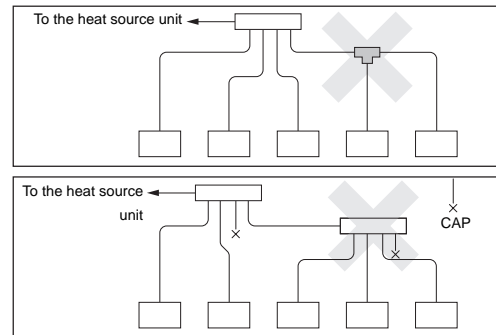

- Either a lack or an excess of refrigerant causes the unit to make an emergency stop. Charge the system with an appropriate amount of refrigerant. When servicing, always check the notes concerning pipe length and amount of additional refrigerant at both locations, the refrigerant volume calculation table on the back of the service panel and the additional refrigerant section on the labels for the combined number of indoor units (Refer to item 9.2. for detailed information on refrigerant piping system).
- Be sure to charge the system using liquid refrigerant.**
- Never use refrigerant to perform an air purge.** Always evacuate using a vacuum pump.
- Always insulate the piping properly. Insufficient insulation will result in a decline in heating/cooling performance, water drops from condensation and other such problems (Refer to item 10.4 for thermal insulation of refrigerant piping).
- When connecting the refrigerant piping, make sure the valve of the heat source unit is completely closed (the factory setting) and do not operate it until the refrigerant piping for the heat source, indoor units and BC controller has been connected, a refrigerant leakage test has been performed and the evacuation process has been completed.
- Braze only with non-oxide brazing material for piping. Failure to do so may damage the compressor. Be sure to perform the non-oxidation brazing with a nitrogen purge. Do not use any commercially available anti-oxidizing agent since it may cause pipe corrosion and degrading of the refrigerant oil. Please contact Mitsubishi Electric for more details.** (Refer to item 10.2. for details of the piping connection and valve operation)
- Never perform heat source unit piping connection work when it is raining.**

⚠ Warning:

When installing and moving the unit, do not charge the system with any other refrigerant other than the refrigerant specified on the unit.

- Mixing of a different refrigerant, air, etc. may cause the refrigerant cycle to malfunction and may result in severe damage.

⚠ Caution:

- **Use a vacuum pump with a reverse flow check valve.**
 - If the vacuum pump does not have a reverse flow check valve, the vacuum pump oil may flow back into the refrigerant cycle and cause deterioration of the refrigerant oil.
- **Do not use the tools shown below used with conventional refrigerant. (Gauge manifold, charge hose, gas leak detector, check valve, refrigerant charge base, vacuum gauge, refrigerant recovery equipment)**
 - Mixing of conventional refrigerant and refrigerant oil may cause the refrigerant oil to deteriorate.
 - Mixing of water will cause the refrigerant oil to deteriorate.
 - R410A refrigerant does not contain any chlorine. Therefore, gas leak detectors for conventional refrigerants will not react to it.
- **Manage the tools used for R410A more carefully than normal.**
 - If dust, dirt, or water gets in the refrigerant cycle, the refrigerant oil will deteriorate.
- **Never use existing refrigerant piping.**
 - The large amount of chlorine in conventional refrigerant and refrigerant oil in the existing piping will cause the new refrigerant to deteriorate.
- **Store the piping to be used during installation indoors and keep both ends of the piping sealed until just before brazing.**
 - If dust, dirt, or water gets into the refrigerant cycle, the oil will deteriorate and the compressor may fail.
- **Do not use a charging cylinder.**
 - Using a charging cylinder may cause the refrigerant to deteriorate.
- **Do not use special detergents for washing piping.**

9.2. Refrigerant piping system

Connection example

[Fig. 9.2.1] (P.4)

[A] Heat source model	[B] Liquid side
[C] Gas side	[E] Total capacity of indoor units
[G] Liquid pipe	[H] Gas pipe
[I] Model number	[J] Downstream unit model total
[K] The 1st branch of P450 – P650	[L] The 1st branch of P700, P750, P800
[M] Joint	
[N] 4-Branching header (Downstream unit model total <= 200)	
[O] 8-Branching header (Downstream unit model total <= 400)	
[P] 10-Branching header (Downstream unit model total <= 650)	
[Q] Heat source twinning kit	
[A] Heat source unit	[B] First branch
[C] Indoor unit	[D] Cap
[E] Heat source twinning kit	

*1 ø12.7 for over 90 m

*2 ø12.7 for over 40 m

*3 The pipe sizes listed in columns A1 to A3 in this table correspond to the sizes for the models listed in the unit 1, 2, and 3 columns. When the order of the models for unit 1, 2, and 3 change, make sure to use the appropriate pipe size.

[Fig. 9.2.2] (P.5)

[A] Heat source model	[D] High-pressure side
[E] Low-pressure side	[F] Total capacity of indoor units
[G] Liquid pipe	[H] Gas pipe
[I] Model number	[J] Downstream unit model total
[Q] Heat source twinning kit	[R] High-pressure gas pipe
[S] Low-pressure gas pipe	
[A] Heat source unit	[B] BC controller (standard)
[C] BC controller (main)	[D] BC controller (sub)
[E] Indoor unit (15 – 80)	[F] Indoor unit (100 – 250)
[G] Heat source twinning kit	

*1 The pipe sizes listed in columns A1 to A2 in this table correspond to the sizes for the models listed in the unit 1 and 2 columns. When the order of unit 1 and 2 is changed, make sure to use the appropriate pipe size for the model.

Precautions for heat source unit combinations

Refer to [Fig. 9.2.3] for the positioning of twinning pipes.

[Fig. 9.2.3] (P.7)

- <A> When the piping on the heat source unit side (from the twinning pipe) exceeds 2 m, ensure a trap (gas pipe only) within 2 m. Make sure the height of the trap is 200 mm or more.
 - If there is no trap, oil can accumulate inside the pipe, causing a shortage of oil and may damage the compressor. (for PQHY-P-YSHM-A)
- Pipe connection example (for PQHY-P-Y(S)HM-A)
 - [A] Indoor unit
 - [B] Trap (gas pipe only)
 - [C] Within 2 m
 - [D] Twinning pipe
 - [E] Pipes on site
 - [F] Twinning kit
 - [G] Straight run of pipe that is 500 mm or more

Precautions for heat source unit combinations

Refer to [Fig. 9.2.4] for the positioning of twinning pipes.

[Fig. 9.2.4] (P.7)

- <A> The piping from the heat source units to twinning pipe must be made to slope downwards the twinning pipe. (both the liquid and the gas side for PQHY-P-YSHM-A, the high-pressure side only for PQRV-P-YSHM-A)
- Slope of twinning pipes (for PQHY-P-YSHM-A)
 - Make sure the slope of the twinning pipes are at an angle within $\pm 15^\circ$ to the horizontal plane.
 - If the slope exceeds the specified angle, the unit may be damaged.
- <C> Pipe connection example (for PQRV-P-YSHM-A)
 - [A] Downward slope
 - [B] Upward slope
 - [C] BC controller (standard or main)
 - [D] Twinning pipe
 - [E] Slope of the twinning pipe is at an angle within $\pm 15^\circ$ to the ground
 - [F] Twinning pipe (low-pressure side)
 - [G] Twinning pipe (high-pressure side)
 - [H] On-site piping (low-pressure connecting pipe: between heat source units)
 - [I] On-site piping (low-pressure main pipe: to BC controller)
 - [J] On-site piping (high-pressure main pipe: to BC controller)

10. Additional refrigerant charge

At the time of shipping, the heat source unit is charged with refrigerant. This charge does not include the amount needed for extended piping and additional charging of each refrigerant line will be required on site. In order that future servicing may be properly provided, always keep a record of the size and length of each refrigerant line and the amount of additional charge by writing it in the space provided on the heat source unit.

For PQHY-P-Y(S)HM-A

<Additional Charge>

$$\begin{array}{c} \text{Additional} \\ \text{refrigerant charge} \\ \text{(kg)} \end{array} = \begin{array}{c} \text{Liquid pipe size} \\ \text{Total length of} \\ \text{\textcircled{1}9.05 \times 0.29} \\ \text{(m) \times 0.29 (kg/m)} \end{array} + \begin{array}{c} \text{Liquid pipe size} \\ \text{Total length of} \\ \text{\textcircled{1}5.88 \times 0.2} \\ \text{(m) \times 0.2 (kg/m)} \end{array} + \begin{array}{c} \text{Liquid pipe size} \\ \text{Total length of} \\ \text{\textcircled{1}2.7 \times 0.12} \\ \text{(m) \times 0.12 (kg/m)} \end{array} \\ + \begin{array}{c} \text{Liquid pipe size} \\ \text{Total length of} \\ \text{\textcircled{9}9.52 \times 0.06} \\ \text{(m) \times 0.06 (kg/m)} \end{array} + \begin{array}{c} \text{Liquid pipe size} \\ \text{Total length of} \\ \text{\textcircled{6}6.35 \times 0.024} \\ \text{(m) \times 0.024 (kg/m)} \end{array} + \alpha$$

<Example>

Indoor	1: 125	A: \textcircled{1}2.7	40 m	a: \textcircled{9}9.52	10 m	} At the conditions below:
	2: 100	B: \textcircled{9}9.52	10 m	b: \textcircled{9}9.52	5 m	
	3: 40	C: \textcircled{9}9.52	15 m	c: \textcircled{6}6.35	10 m	
	4: 32	D: \textcircled{9}9.52	10 m	d: \textcircled{6}6.35	10 m	
	5: 63			e: \textcircled{9}9.52	10 m	

The total length of each liquid line is as follows:

\textcircled{1}2.7: A = 40 = 40 m

\textcircled{9}9.52: B + C + D + a + b + e = 10 + 15 + 10 + 10 + 5 + 10 = 60 m

\textcircled{6}6.35: c + d = 10 + 10 = 20 m

Therefore,

<Calculation example>

Additional refrigerant charge

$$= 40 \times 0.12 + 60 \times 0.06 + 20 \times 0.024 + 2.5 = 11.4 \text{ kg}$$

Value of α

Total capacity of connecting indoor units	α
Models ~ 80	2.0 kg
Models 81 ~ 160	2.5 kg
Models 161 ~ 330	3.0 kg
Models 331 ~ 390	3.5 kg
Models 391 ~ 480	4.5 kg
Models 481 ~ 630	5.0 kg
Models 631 ~ 710	6.0 kg
Models 711 ~	8.0 kg

10.1. Calculation of additional refrigerant charge

- Calculate the amount of additional charge based on the length of the piping extension and the size of the refrigerant line.
- Use the table below as a guide for calculating the amount of additional charging and then charge the system accordingly.
- If the calculation results in a fraction of less than 0.1 kg, round up to the next 0.1 kg. For example, if the result of the calculation was 27.73 kg, round the result up to 27.8 kg.

For PQRY-P-Y(S)HM-A

<Additional charge>

$$\begin{array}{c} \text{Additional} \\ \text{refrigerant charge} \\ \text{(kg)} \end{array} = \begin{array}{c} \text{High-pressure} \\ \text{pipe size} \\ \text{Total length of} \\ \text{\textcircled{2}28.58 \times 0.36} \\ \text{(m) \times 0.36 (kg/m)} \end{array} + \begin{array}{c} \text{High-pressure} \\ \text{pipe size} \\ \text{Total length of} \\ \text{\textcircled{2}22.2 \times 0.23} \\ \text{(m) \times 0.23 (kg/m)} \end{array} + \begin{array}{c} \text{High-pressure} \\ \text{pipe size} \\ \text{Total length of} \\ \text{\textcircled{1}9.05 \times 0.16} \\ \text{(m) \times 0.16 (kg/m)} \end{array} \\ + \begin{array}{c} \text{High-pressure} \\ \text{pipe size} \\ \text{Total length of} \\ \text{\textcircled{1}5.88 \times 0.11} \\ \text{(m) \times 0.11 (kg/m)} \end{array} + \begin{array}{c} \text{Liquid Piping Size} \\ \text{Total length of} \\ \text{\textcircled{1}5.88 \times 0.2} \\ \text{(m) \times 0.2 (kg/m)} \end{array} + \begin{array}{c} \text{Liquid Piping Size} \\ \text{Total length of} \\ \text{\textcircled{1}2.7 \times 0.12} \\ \text{(m) \times 0.12 (kg/m)} \end{array} \\ + \begin{array}{c} \text{Liquid Piping Size} \\ \text{Total length of} \\ \text{\textcircled{9}9.52 \times 0.06} \\ \text{(m) \times 0.06 (kg/m)} \end{array} + \begin{array}{c} \text{Liquid Piping Size} \\ \text{Total length of} \\ \text{\textcircled{6}6.35 \times 0.024} \\ \text{(m) \times 0.024 (kg/m)} \end{array} \\ + \begin{array}{c} \text{BC controller} \\ \text{(Standard/Main)} \\ \text{3.0kg} \end{array} + \begin{array}{c} \text{BC controller} \\ \text{(Sub) Total Units} \\ \text{1} \\ \text{2} \end{array} + \begin{array}{c} \text{BC controller} \\ \text{(Sub) Per Unit} \\ \text{1.0 kg} \\ \text{2.0 kg} \end{array}$$

Total Capacity of Connected Indoor Units	Per Indoor Unit
~80	2.0kg
81~160	2.5kg
161~330	3.0kg
331~390	3.5kg
391~480	4.5kg
481~630	5.0kg
631~710	6.0kg
711~800	8.0kg
801~890	9.0kg
891~	10.0kg

<Example>

Indoor	1: 80	A: \textcircled{2}28.58	40 m	a: \textcircled{9}9.52	10 m	} At the conditions below:
	2: 250	B: \textcircled{9}9.52	10 m	b: \textcircled{9}9.52	5 m	
	3: 32	C: \textcircled{9}9.52	20 m	c: \textcircled{6}6.35	5 m	
	4: 40	D: \textcircled{9}9.52	5 m	d: \textcircled{6}6.35	10 m	
	5: 32	E: \textcircled{9}9.52	5 m	e: \textcircled{6}6.35	5 m	
	6: 63	F: \textcircled{2}22.2	3 m	f: \textcircled{9}9.52	5 m	
		G: \textcircled{1}19.05	1 m			

The total length of each liquid line is as follows:

\textcircled{2}28.58: A = 40 m

\textcircled{2}22.2: F = 3 m

\textcircled{1}9.05: G = 1 m

\textcircled{9}9.52: C + D + E + a + b + f = 50 m

\textcircled{6}6.35: c + d + e = 20 m

Therefore,

<Calculation example>

Additional refrigerant charge

$$= 40 \times 0.36 + 3 \times 0.23 + 1 \times 0.16 + 50 \times 0.06 + 20 \times 0.024 + 2 + 2 + 5 = 27.8 \text{ kg}$$

■ Limitation of the amount of refrigerant to be charged (for PQRY-P-Y(S)HM-A only)

The above calculation result of the amount of refrigerant to be charged must become below the value in the table below.

Heat source unit model	P200	P250	P300	P400	P450	P500	P550	P600
Maximum amount of refrigerant ^{*1} kg	26.3	32.8	33.8	45.5	47.0	58.2	67.4	70.9

*1: Amount of additional refrigerant to be charged on site

10.2. Precautions concerning piping connection and valve operation

- Conduct piping connection and valve operation accurately and carefully.
- **Removing the pinched connecting pipe**

When shipped, a pinched connecting pipe is attached to the on site high-pressure and low-pressure valves to prevent gas leakage.

Take the following steps ① through ④ to remove the pinched connecting pipe before connecting refrigerant pipes to the heat source unit.

- ① Check that the refrigerant service valve is fully closed (turned clockwise all the way).
- ② Connect a charging hose to the service port on the low-pressure/high-pressure refrigerant service valve, and extract the gas in the pipe section between the refrigerant service valve and the pinched connecting pipe (Tightening torque 12N·m).
- ③ After vacuuming gas from the pinched connecting pipe, sever the pinched connecting pipe at the location shown in [Fig.10.2.1] and drain the refrigerant.
- ④ After completing ② and ③ heat the brazed section to remove the pinched connecting pipe.

[Fig. 10.2.1] (P.8)

- <A> Refrigerant service valve
(Liquid side/brazed type for PQHY-P-Y(S)HM-A)
(High-pressure side/brazed type for PQRYP-Y(S)HM-A)
- Refrigerant service valve
(Gas side/brazed type for PQHY-P-Y(S)HM-A)
(Low-pressure side/brazed type for PQRYP-Y(S)HM-A)
- Ⓐ Shaft
- Ⓑ Service port
- Ⓒ Cap
- Ⓓ Pinched connecting pipe severing portion
- Ⓔ Pinched connecting pipe brazing portion

⚠ Warning:

- **The sections between the refrigerant service valves and the pinched connecting pipes are filled with gas and refrigerant oil. Extract the gas and refrigerant oil in the above-mentioned pipe section before heating the brazed section to remove the refrigerant service valve pinched connecting pipe.**
- If the brazed section is heated without first extracting the gas and refrigerant oil, the pipe may burst or the pinched connecting pipe may blow off and ignite the refrigerant oil, causing serious injury.

⚠ Caution:

- **Place a wet towel on the refrigerant service valve before heating the brazed section to keep the temperature of the valve from exceeding 120 °C.**
- **Direct the flame away from the wiring and metal sheets inside the unit to prevent heat damage.**

⚠ Caution:

- **Do not vent R410A into the atmosphere.**
- **R410A is a Fluorinated Greenhouse gas, covered by the Kyoto Protocol, with a Global Warming Potential (GWP) = 1975.**
- **Refrigerant pipe connection**
This product includes connecting pipes for front piping. (Refer to [Fig.10.2.2]) Check the high-pressure/low-pressure piping dimensions before connecting the refrigerant pipe.
Refer to item 9.2 Refrigerant piping system for piping dimensions. Make sure that the refrigerant pipe is not touching other refrigerants pipes, unit panels, or base plates.
Be sure to use non-oxidative brazing when connecting pipes.
Be careful not to burn the wiring and plate when brazing.

<Refrigerant piping connection examples>

[Fig.10.2.2] (P.8)

- ① Connecting pipe (ID 19.05, ID 15.88) <Included with heat source unit>
 - ② Connecting pipe (ID 25.4, ID 19.05) <Included with heat source unit>
 - ③ Connecting pipe (ID 25.4, ID 22.2) <Included with heat source unit>
 - ④ Connecting pipe (ID 19.05, OD 25.4) <Included with heat source unit>
- <A> Front pipe routing
 - Low-pressure side PQRYP-Y(S)HM-A (Gas side PQHY-P-Y(S)HM-A)
 - <C> High-pressure side PQRYP-Y(S)HM-A (Liquid side PQHY-P-Y(S)HM-A)
 - Ⓐ Shape
 - Ⓑ When not attaching a low-pressure twinning pipe
 - Ⓒ When attaching a low-pressure twinning pipe (PQRYP-YSHM-A ONLY)
 - Ⓓ Refrigerant service valve piping
 - Ⓔ On-site piping (low-pressure connecting pipe)
 - Ⓕ On-site piping (high-pressure connecting pipe)
 - Ⓖ Twinning kit (sold separately)
 - Ⓗ On-site piping (low-pressure connecting pipe: to BC controller)
 - Ⓘ On-site piping (low-pressure connecting pipe: to heat source unit)
 - Ⓙ 75 mm (reference measurement)
 - Ⓚ ID ø25.4 side
 - Ⓛ Severing portion

*1 For the attachment of the Twinning pipe (sold separately), refer to the instructions included in the kit.

*2 Connection pipe is not used when the Twinning Kit is attached.

*3 Use a pipe cutter to sever.

• Pipe routing (for PQHY-P-YHM-A)

Ⓐ	P200 : Expand the high-pressure side on-site piping (ID9.52) and connect to the refrigerant service valve piping.
Ⓑ	P200 : Use the included connecting pipe ②, ④ to connect. P250, P300 : Use the included connecting pipe ③ to connect.

• Pipe routing (for PQRYP-YHM-A)

Ⓐ	P200 : Use the included connecting pipe ① to connect. P250, P300 : Expand the high-pressure side on-site piping (ID19.05) and connect to the refrigerant service valve piping.
Ⓑ	P200 : Use the included connecting pipe ② to connect. P250, P300 : Use the included connecting pipe ③ to connect.

Satisfy the minimum insertion depth in the table below when expanding on-site piping

Pipe diameter (mm)	Minimum insertion depth (mm)
5 or more less than 8	6
8 or more less than 12	7
12 or more less than 16	8
16 or more less than 25	10
25 or more less than 35	12
35 or more less than 45	14

- After evacuation and refrigerant charging, ensure that the handle is fully open. If operating with the valve closed, abnormal pressure will be imparted to the high- or low-pressure side of the refrigerant circuit, giving damage to the compressor, four-way valve, etc.
- Determine the amount of additional refrigerant charge by using the formula, and charge refrigerant additionally through the service port after completing piping connection work.
- After completing work, tighten the service port and cap securely so as not to generate any gas leakage. (Refer to the table on the below for appropriate tightening torque.)

Appropriate tightening torque:

Outer diameter of copper pipe (mm)	Cap (N·m)	Shaft (N·m)	Size of hexagonal wrench (mm)	Service port (N·m)
ø9.52	15	6	4	12
ø12.7	20	9	4	
ø15.88	25	15	6	
ø19.05	25	30	8	
ø25.4	25	30	8	

⚠ Caution:

- **Keep the valve closed until refrigerant charging to the pipes to be added on site has been completed. Opening the valve before charging the refrigerant may cause damage to the unit.**
- **Do not use a leak detection additive.**

10.3. Airtight test, evacuation, and refrigerant charging

① **Airtight test**

Perform with the valve of the heat source unit closed, and pressurize the connection piping and the indoor unit from the service port provided on the valve of the heat source unit. (Always pressurize from both the high-pressure pipe and the low-pressure pipe service ports.)

[Fig. 10.3.1] (P.9)

- | | | |
|-----------------------|------------------------|----------------------|
| (A) Nitrogen gas | (B) To indoor unit | (C) System analyzer |
| (D) Low knob | (E) Hi knob | (F) Valve |
| (G) Low-pressure pipe | (H) High-pressure pipe | (I) Heat source unit |
| (J) Service port | | |

Observe the following restrictions when conducting an air tightness test to prevent negative effects on the refrigerating machine oil. Also, with nonazeotropic refrigerant (R410A), gas leakage causes the composition to change and affects performance. Therefore, perform the airtightness test cautiously.

Airtight test procedure	Restriction
<p>(1) After pressurizing to the design pressure (4.15 MPa) using nitrogen gas, allow it to stand for about one day. If the pressure does not drop, airtightness is good. However, if the pressure drops, since the leaking point is unknown, the following bubble test may also be performed.</p> <p>(2) After the pressurization described above, spray the flare connection parts, brazed parts, and other parts that may leak with a bubbling agent (Kyuboflex, etc.) and visually check for bubbles.</p> <p>(3) After the airtight test, wipe off the bubbling agent.</p>	<ul style="list-style-type: none"> • If a flammable gas or air (oxygen) is used as the pressurization gas, it may catch fire or explode.

⚠ Caution:

Only use refrigerant R410A.

- The use of other refrigerants such as R22 or R407C, which contains chlorine, will deteriorate the refrigerating machine oil or cause the compressor to malfunction.

② **Evacuation**

Evacuate with the valve of the heat source unit closed and evacuate both the connection piping and the indoor unit from the service port provided on the valve of the heat source unit using a vacuum pump. (Always evacuate from the service port of both the high-pressure pipe and the low-pressure pipe.) After the vacuum reaches 650 Pa [abs], continue evacuation for at least one hour or more. Then, stop the vacuum pump and leave it for 1 hour. Ensure the degree of vacuum has not increased. **(If the degree of vacuum increase is larger than 130 Pa, water might have entered. Apply pressure to dry nitrogen gas up to 0.05 MPa and vacuum again.)** Finally, seal in with the liquid refrigerant through the high-pressure pipe, and adjust the low-pressure piping to obtain an appropriate amount of the refrigerant during operation.

* Never perform air purging using refrigerant.

[Fig. 10.3.2] (P.9)

- | | | |
|---------------------|-----------------------|------------------------|
| (A) System analyzer | (B) Low knob | (C) Hi knob |
| (D) Valve | (E) Low-pressure pipe | (F) High-pressure pipe |
| (G) Service port | (H) Three-way joint | (I) Valve |
| (J) Valve | (K) R410A cylinder | (L) Scale |
| (M) Vacuum pump | (N) To indoor unit | (O) Heat source unit |

Note:

- **Always add an appropriate amount of refrigerant. Also always charge the system with liquid refrigerant.**
- **Use a gauge manifold, charging hose, and other parts for the refrigerant indicated on the unit.**
- **Use a gravimeter. (One that can measure down to 0.1 kg.)**
- **Use a vacuum pump with a reverse flow check valve.**
(Recommended vacuum gauge: ROBINAIR 14830A Thermistor Vacuum Gauge)
Also use a vacuum gauge that reaches 65 Pa [abs] or below after operating for five minutes.

③ **Refrigerant Charging**

Since the refrigerant used with the unit is nonazeotropic, it must be charged in the liquid state. Consequently, when charging the unit with refrigerant from a cylinder, if the cylinder does not have a syphon pipe, charge the liquid refrigerant by turning the cylinder upside-down as shown in Fig.10.3.3. If the cylinder has a syphon pipe like that shown in the picture on the right, the liquid refrigerant can be charged with the cylinder standing upright. Therefore, give careful attention to the cylinder specifications. If the unit should be charged with gas refrigerant, replace all the refrigerant with new refrigerant. Do not use the refrigerant remaining in the cylinder.

[Fig. 10.3.3] (P.9)

- | | |
|-----------------|--|
| (A) Syphon pipe | (B) In case of the R410A cylinder having no syphon pipe. |
|-----------------|--|

10.4. Thermal insulation of refrigerant piping

Be sure to add insulation work to refrigerant piping by covering high-pressure pipe and low-pressure pipe separately with enough thickness heat-resistant polyethylene, so that no gap is observed in the joint between indoor unit and insulating material, and insulating materials themselves. When insulation work is insufficient, there is a possibility of condensation drip, etc. Pay special attention to insulation work in the ceiling plenum.

[Fig. 10.4.1] (P.9)

- (A) Steel wire (B) Piping
(C) Asphaltic oily mastic or asphalt (D) Heat insulation material A
(E) Outer covering B

Heat insulation material A	Glass fiber + Steel wire	
	Adhesive + Heat - resistant polyethylene foam + Adhesive tape	
Outer covering B	Indoor	Vinyl tape
	Floor exposed	Water-proof hemp cloth + Bronze asphalt
	Heat source	Water-proof hemp cloth + Zinc plate + Oily paint

Note:

- When using polyethylene as a covering material, asphalt roofing shall not be required.
- No heat insulation must be provided to electric wires.

[Fig. 10.4.2] (P.9)

- (A) High-pressure pipe (B) Low-pressure pipe (C) Electric wire
(D) Finishing tape (E) Insulator

[Fig. 10.4.3] (P.9)

Penetrations

[Fig. 10.4.4] (P.9)

- <A> Inner wall (concealed) Outer wall
<C> Outer wall (exposed) <D> Floor (waterproofing)
<E> Roof pipe shaft
<F> Penetrating portion on fire limit and boundary wall
(A) Sleeve (B) Heat insulating material
(C) Lagging (D) Caulking material
(E) Band (F) Waterproofing layer
(G) Sleeve with edge (H) Lagging material
(I) Mortar or other incombustible caulking
(J) Incombustible heat insulation material

When filling a gap with mortar, cover the penetration part with steel plate so that the insulation material will not be caved in. For this part, use incombustible materials for both insulation and covering. (Vinyl covering should not be used.)

- Insulation materials for the pipes to be added on site must meet the following specifications:

Heat source unit -BC controller for PQRY-P-Y(S)HM-A	High-pressure pipe	10 mm or more
	Low-pressure pipe	20 mm or more
BC controller -indoor unit for PQRY-P-Y(S)HM-A	Pipe size 6.35 mm to 25.4 mm	10 mm or more
	Pipe size 28.58 mm to 38.1 mm	15 mm or more
Heat source unit -indoor unit for PQHY-P-Y(S)HM-A	Pipe size 6.35 mm to 25.4 mm	10 mm or more
	Pipe size 28.58 mm to 38.1 mm	15 mm or more
Temperature Resistance	100°C min.	

* Installation of pipes in a high-temperature high-humidity environment, such as the top floor of a building, may require the use of insulation materials thicker than the ones specified in the chart above.

* When certain specifications presented by the client must be met, ensure that they also meet the specifications on the chart above.

11. Wiring (For details, refer to the installation manual of each unit and controller.)

11.1. Caution

- Follow ordinance of your governmental organization for technical standard related to electrical equipment, wiring regulations and guidance of each electric power company.
- Wiring for control (hereinafter referred to as transmission line) shall be (5 cm or more) apart from power source wiring so that it is not influenced by electric noise from power source wiring (Do not insert transmission line and power source wire in the same conduit).
- Be sure to provide designated grounding work to the heat source unit.
- Give some allowance to wiring for the electrical control box on the indoor and heat source units, because these boxes are sometimes removed at the time of service work.
- Never connect the main power source to the terminal block of the transmission line. If connected, electrical parts will burn out.
- Use 2-core shield cable for the transmission line. If transmission lines of different systems are wired with the same multicore cable, the resultant poor transmitting and receiving will cause erroneous operations.
- Only the transmission line specified should be connected to the terminal block for heat source unit transmission.
Erroneous connection does not allow the system to operate.
- In the case of connecting with an upper class controller or to conduct group operation in different refrigerant systems, the control line for transmission is required between the heat source units in different refrigerant systems.
Connect this control line between the terminal blocks for centralized control (2-wire line with no polarity).
- Grouping is set by operating the remote controller.

11.2. Control box and connecting position of wiring

① Heat source unit

- Remove the front panel of the control box by removing the 4 screws and pushing it up a little before pulling it out.
- Connect the indoor - heat source transmission line to the terminal block (TB3) for the indoor - heat source transmission line.
If multiple heat source units are connected in the same refrigerant system, daisy-chain TB3 (M1, M2, ⚡ Terminal) on the heat source units. Connect the indoor - heat source transmission line for the heat source units to TB3 (M1, M2, ⚡ Terminal) of only one of the heat source units.

- Connect the transmission lines for centralized control (between the centralized control system and the heat source unit of different refrigerant systems) to the terminal block for centralized control (TB7). If the multiple heat source units are connected to the same refrigerant system, daisy-chain TB7 (M1, M2, S Terminal) on the heat source units in the same refrigerant system. (*1)
*1: If TB7 on the heat source unit in the same refrigerant system is not daisy-chained, connect the transmission line for centralized control to TB7 on the OC (*2). If the OC is out of order, or if the centralized control is being conducted during the power supply shut-off, daisy-chain TB7 on the OC and OS (In the case that the heat source unit whose power supply connector CN41 on the control board has been replaced with CN40 is out of order or the power is shut-off, centralized control will not be conducted even when TB7 is daisy-chained).
*2: OC and OS of the heat source units in the same refrigerant system are automatically identified. They are identified as OC and OS in descending order of capacity (If the capacity is the same, they will be in ascending order of their address number).
- In the case of indoor-heat source transmission line, connect the shield ground to the grounding terminal (⚡). In the case of transmission lines for centralized control, connect it to the shield terminal (S) on the terminal block for centralized control (TB7). Furthermore, in the case of the heat source units whose power supply connector CN41 is replaced with CN40, short circuit the shield terminal (S) and the grounding terminal (⚡) in addition to the above.
- Fix the connected wires securely in place with the cable strap at the bottom of the terminal block. External force applied to the terminal block may damage it resulting in a short circuit, ground fault, or a fire.

[Fig. 11.2.1] (P.10)

- (A) Power source (B) Transmission line
(C) Earth screw

[Fig. 11.2.2] (P.10)

- (A) Cable strap (B) Power source cable
(C) Ground terminal for connection to field wiring

② Conduit tube installation

- Close by hammering the knockout holes for the conduit tube located on the base and the bottom part of the front panel.
- When installing the conduit tube directly through the knockout holes, remove the burr and protect the tube with masking tape.
- Use the conduit tube to narrow down the opening if there is a possibility of small animals entering the unit.

11.3. Wiring transmission cables

① Types of control cables

1. Wiring transmission cables

- Types of transmission cables: Shielding wire CVVS, CPEVS or MVVS
- Cable diameter: More than 1.25 mm²
- Maximum wiring length: Within 200 m
- Maximum length of transmission lines for centralized control and indoor/heat source transmission lines (Maximum length via heat source units): 500 m MAX
The maximum length of the wiring between power supply unit for transmission lines (on the transmission lines for centralized control) and each heat source unit and system controller is 200 m.

2. Remote control cables

• M-NET Remote Controller

Kind of remote control cable	Sheathed 2-core cable (unshielded) CVV
Cable diameter	0.3 to 1.25 mm ² (0.75 to 1.25 mm ²)*
Remarks	When 10 m is exceeded, use cable with the same specifications as 1. Wiring transmission cables.

• MA Remote Controller

Kind of remote control cable	Sheathed 2-core cable (unshielded) CVV
Cable diameter	0.3 to 1.25 mm ² (0.75 to 1.25 mm ²)*
Remarks	Within 200 m

* Connected with simple remote controller.

② Wiring examples

- Controller name, symbol and allowable number of controllers.

Name		Code	Possible unit connections
Heat source unit	Main unit	OC	– (*2)
	Sub unit	OS	– (*2)
BC controller	Main unit	BC	One controller for one OC
	Sub unit	BS	Zero, one or two controllers for one OC
Indoor unit	Indoor unit controller	IC	1 to 50 units per 1 OC (*1)
Remote controller	Remote controller (*1)	RC	2 units maximum per group
Other	Transmission booster unit	RP	0 to 2 units per 1 OC (*1)

*1 A transmission booster (RP) may be required depending on the number of connected indoor unit controllers.

*2 OC and OS of the heat source units in the same refrigerant system are automatically identified. They are identified as OC and OS in descending order of capacity. (If the capacity is the same, they will be in ascending order of their address number.)

Example of a group operation system with multiple heat source units (Shielding wires and address setting are necessary.)

<Examples of transmission cable wiring>

[Fig. 11.3.1] [Fig. 11.3.4] M-NET Remote Controller (P.10, 12)

*1: When the power supply unit is not connected to the transmission line for centralized control, disconnect the male power supply connector (CN41) from ONE heat source unit in the system and connect it to CN40.

*2: If a system controller is used, set SW2-1 on all of the heat source units to ON.

[Fig. 11.3.2] [Fig. 11.3.5] MA Remote Controller (P.11, 13)

<A> Change the jumper connector from CN41 to CN40

 SW2-1:ON

<C> Keep the jumper connector on CN41

(A) Group 1 (B) Group 3 (C) Group 5 (D) Shielded wire (E) Sub remote controller

() Address

[Fig. 11.3.6] Combination of heat source units and transmission booster unit (P.13)

- () Address
- Daisy-chain terminals (TB3) on heat source units in the same refrigerant system together.
- Leave the power jumper connector on CN41 as it is. When connecting a system controller to the transmission line (TB7) for centralized control, refer to [Fig. 11.3.1]~[Fig. 11.3.4], or DATA BOOK.

<Wiring Method and Address Settings>

- Always use shielded wire when making connections between the heat source unit (OC) and the indoor unit (IC), as well for all OC-OC, OC-OS and IC-IC wiring intervals.
- Use feed wiring to connect terminals M1 and M2 and the earth terminal \uparrow on the transmission line terminal block (TB3) of each heat source unit (OC) to terminals M1, M2 and terminal S on the transmission line block of the indoor unit (IC). For OC and OS, connect TB3 to TB3.
- Connect terminals 1 (M1) and 2 (M2) on the transmission line terminal block of the indoor unit (IC) that has the most recent address within the same group to the terminal block on the remote controller (RC).
- Connect together terminals M1, M2 and terminal S on the terminal block for central control (TB7) for the heat source unit in a different refrigerant system (OC). For OC and OS in the same refrigerant system, connect TB7 to TB7.
- When the power supply unit is not installed on the central control transmission line, change the jumper connector on the control board from CN41 to CN40 on only one heat source unit in the system.
- Connect the terminal S on the terminal block for central control (TB7) for the heat source unit (OC) for the unit into which the jumper connector was inserted into CN40 in the step above to the earth terminal \uparrow in the electrical component box.
- Set the address setting switch as follows.

* To set the heat source unit address to 100, the heat source address setting switch must be set to 50.

Unit	Range	Setting Method
Indoor unit (Main)	01 to 50	Use the most recent address within the same group of indoor units. With an R2 system with sub BC controllers, set the indoor unit address in the following order: ① Indoor units connected to the main BC controller ② Indoor units connected to BC sub controller 1 ③ Indoor units connected to BC sub controller 2 Set the indoor unit addresses so that all the addresses of ① are smaller than those of ②, and that all the addresses of ② are smaller than those of ③.
Indoor unit (Sub)	01 to 50	Use an address, other than that of the IC (Main) from among the units within the same group of indoor units. This must be in sequence with the IC (Main)
Heat source Unit (OC, OS)	51 to 100	Set the addresses of the heat source units in the same refrigerant system in the order of sequential number. OC and OS are automatically identified. (*1)
BC controller (Main)	51 to 100	Heat source unit address plus 1. When the set indoor unit address duplicates the address of another indoor unit, set the new address to a vacant address within the setting range.
BC controller (Sub)	51 to 100	Lowest address within the indoor units connected to the BC controller (sub) plus 50
M-NET R/C (Main)	101 to 150	Set at an IC (Main) address within the same group plus 100
M-NET R/C (Sub)	151 to 200	Set at an IC (Main) address within the same group plus 150
MA R/C	-	Unnecessary address setting (Necessary main/sub setting)

- h. The group setting operations among the multiple indoor units is done by the remote controller (RC) after the electrical power has been turned on.
- i. When the centralized remote controller is connected to the system, set centralized control switches (SW2-1) on control boards in all heat source units (OC, OS) to "ON".
- *1 OC and OS of the heat source units in the same refrigerant system are automatically identified. They are identified as OC and OS in descending order of capacity (If the capacity is the same, they are identified in the ascending order of their address number).

<Permissible Lengths>

① **M-NET Remote controller [Fig. 11.3.4] (P.12)**

- Max length via heat source units: $L_1+L_2+L_3+L_4$ and $L_1+L_2+L_3+L_5$ and $L_1+L_2+L_6 \leq 500$ m (1.25 mm² or more)
- Max transmission cable length: L_1 and L_3+L_4 and L_3+L_5 and L_6 and $L_2+L_6 \leq 200$ m (1.25 mm² or more)
- Remote controller cable length: $\ell_1, \ell_2, \ell_3, \ell_4 \leq 10$ m (0.3 to 1.25 mm²)
If the length exceeds 10 m, use a 1.25 mm² shielded wire. The length of this section (L_8) should be included in the calculation of the maximum length and overall length.

② **MA Remote controller [Fig. 11.3.5] (P.13)**

- Max length via heat source unit (M-NET cable): $L_1+L_2+L_3+L_4$ and $L_1+L_2+L_6 \leq 500$ m (1.25 mm² or more)
- Max transmission cable length (M-NET cable): L_1 and L_3+L_4 and L_6 and $L_2+L_6 \leq 200$ m (1.25 mm² or more)
- Remote controller cable length: m_1+m_2 and $m_1+m_2+m_3+m_4 \leq 200$ m (0.3 to 1.25 mm²)

③ **Transmission booster [Fig. 11.3.6] (P.13)**

- Max transmission cable length (M-NET cable): ① $L_{11} + L_{12} + L_{13} + L_{14} + L_{16} + L_{17} \leq 200$ m (1.25 mm²)
② $L_{11} + L_{12} + L_{13} + L_{14} + L_{16} + L_{18} \leq 200$ m (1.25 mm²)
③ $L_{11} + L_{12} + L_{13} + L_{15} \leq 200$ m (1.25 mm²)
④ $L_{17} + L_{16} + L_{14} + L_{15}, L_{15} + L_{14} + L_{16} + L_{18} \leq 200$ m (1.25 mm²)
- Remote controller cable length: $\ell_1, \ell_2 \leq 10$ m (0.3 to 1.25 mm²)
If the length exceeds 10 m, use 1.25 mm² shielded cable and calculate the length of that portion (L_{15} and L_{18}) as within the total extended length and the longest remote length.

11.4. Wiring of main power supply and equipment capacity

Schematic Drawing of Wiring (Example)

[Fig. 11.4.1] (P.13)

- (A) Switch (Breakers for wiring and current leakage) (B) Breakers for current leakage (C) Heat source unit
 (D) Pull box (E) Indoor unit (F) BC controller (standard or main) (F') BC controller (sub)

Thickness of wire for main power supply, capacities of the switch and system impedance

PQHY-P-YHM-A(-BS)	Model	Minimum wire thickness (mm ²)			Breaker for current leakage	Local switch		Breaker for wiring (NFB)	Max. Permissible System Impedance
		Main cable	Branch	Ground		Capacity	Fuse		
Heat source unit	PQHY-P200YHM-A(-BS)	4.0	-	4.0	30A 100mA 0.1sec. or less	25	25	30	*1
	PQHY-P250YHM-A(-BS)	4.0	-	4.0	30A 100mA 0.1sec. or less	25	25	30	*1
	PQHY-P300YHM-A(-BS)	4.0	-	4.0	30A 100mA 0.1sec. or less	25	25	30	*1
Total operating current of the indoor unit	16A or less	1.5	1.5	1.5	20A 30mA 0.1sec. or less	16	16	20	(apply to EN61000-3-3)
	25A or less	2.5	2.5	2.5	30A 30mA 0.1sec. or less	25	25	30	(apply to EN61000-3-3)
	32A or less	4.0	4.0	4.0	40A 30mA 0.1sec. or less	32	32	40	(apply to EN61000-3-3)

PQRY-P-YHM-A(-BS)	Model	Minimum wire thickness (mm ²)			Breaker for current leakage	Local switch		Breaker for wiring (NFB)	Max. Permissible System Impedance
		Main cable	Branch	Ground		Capacity	Fuse		
Heat source unit	PQRY-P200YHM-A(-BS)	4.0	-	4.0	30A 100mA 0.1sec. or less	25	25	30	*1
	PQRY-P250YHM-A(-BS)	4.0	-	4.0	30A 100mA 0.1sec. or less	25	25	30	*1
	PQRY-P300YHM-A(-BS)	4.0	-	4.0	30A 100mA 0.1sec. or less	25	25	30	*1
Total operating current of the indoor unit	16A or less	1.5	1.5	1.5	20A 30mA 0.1sec. or less	16	16	20	(apply to EN61000-3-3)
	25A or less	2.5	2.5	2.5	30A 30mA 0.1sec. or less	25	25	30	(apply to EN61000-3-3)
	32A or less	4.0	4.0	4.0	40A 30mA 0.1sec. or less	32	32	40	(apply to EN61000-3-3)

*1: Meets technical requirements of IEC61000-3-3

- Use dedicated power supplies for the heat source unit and indoor unit. Ensure OC and OS are wired individually.
- Bear in mind ambient conditions (ambient temperature, direct sunlight, rain water, etc.) when proceeding with the wiring and connections.
- The wire size is the minimum value for metal conduit wiring. If the voltage drops, use a wire that is one rank thicker in diameter. Make sure the power-supply voltage does not drop more than 10%.
- Specific wiring requirements should adhere to the wiring regulations of the region.
- Power supply cords of parts of appliances for heat source use shall not be lighter than polychloroprene sheathed flexible cord (design 245 IEC57).
- A switch with at least 3 mm contact separation in each pole shall be provided by the Air Conditioner installer.

⚠ Warning:

- Be sure to use specified wires for connections and ensure no external force is imparted to terminal connections. If connections are not fixed firmly, heating or fire may result.
- Be sure to use the appropriate type of overcurrent protection switch. Note that generated overcurrent may include some amount of direct current.

⚠ Caution:

- Some installation sites may require attachment of an earth leakage breaker for the inverter. If no earth leakage breaker is installed, there is a danger of electric shock.
- Do not use anything other than a breaker and fuse with the correct capacity. Using a fuse or wire of too large capacity may cause malfunction or fire.

Note:

- This device is intended for the connection to a power supply system with a maximum permissible system impedance shown in the above table at the interface point (power service box) of the user's supply.
- The user must ensure that this device is connected only to a power supply system which fulfils the requirement above. If necessary, the user can ask the public power supply company for the system impedance at the interface point.
- This equipment complies with IEC 61000-3-12 provided that the short-circuit power S_{sc} is greater than or equal to $S_{sc}(*2)$ at the interface point between the user's supply and the public system. It is the responsibility of the installer or user of the equipment to ensure, by consultation with the distribution network operator if necessary, that the equipment is connected only to a supply with a short-circuit power S_{sc} greater than or equal to $S_{sc}(*2)$.

$S_{sc}(*2)$

Model	S_{sc} (MVA)	Model	S_{sc} (MVA)
PQRY-P200YHM	1.24	PQHY-P200YHM	1.24
PQRY-P250YHM	1.35	PQHY-P250YHM	1.34
PQRY-P300YHM	1.50	PQHY-P300YHM	1.49

12. Test run

12.1. The following phenomena do not represent faults.

Phenomenon	Display of remote controller	Cause
Indoor unit does not perform cooling (heating) operation.	"Cooling (heating)" flashes	When another indoor unit is performing the heating (cooling) operation, the cooling (heating) operation is not performed.
The auto vane rotates and begins to blow air horizontally.	Normal display	If air has been blowing downward for 1 hour during cooling, the unit may automatically change to horizontal blowing with the control operation of the auto vane. During defrosting or immediately after heating start-up/shut-down, the auto vane automatically rotates to blow air horizontally for a short period of time.
Fan setting changes during heating.	Normal display	Ultra-low speed operation is commenced at thermostat OFF. Light air automatically changes over to set value by time or piping temperature at thermostat ON.
Fan does not stop while operation has been stopped.	No lighting	The fan is set to run for 1 minute after stopping to exhaust residual heat (only in heating).
No setting of fan while start SW has been turned on.	Heat ready	Ultra low-speed operation for 5 minutes after SW ON or until piping temperature becomes 35°C, low speed operation for 2 minutes thereafter, and then set notch is commenced (Hot adjust control).
Indoor unit remote controller shows "H0" or "PLEASE WAIT" indicator for about five minutes when turning ON universal power supply.	"H0" or "PLEASE WAIT" flashes	The system is being started up. Operate remote controller again after "H0" or "PLEASE WAIT" disappears.
Drain pump does not stop when unit is stopped.	Light out	After cooling operation stops, the unit continues to operate drain pump for three minutes and then stops it.
Drain pump continues to operate while unit has been stopped.		Unit continues to operate drain pump if drainage is generated, even after the unit has been stopped.
Indoor unit emits noise when switching from heating to cooling and vice versa.	Normal display	This is a switching sound of the refrigerant circuit and does not imply a problem.
Immediately after startup, the indoor unit emits the sound of the refrigerant flow.	Normal display	Unstable flow of the refrigerant emits a sound. This is temporary and does not imply a problem.
Warm air comes from an indoor unit that is not performing a heating operation.	Normal display	The LEV is slightly open to prevent refrigerant, of the indoor unit that is not performing the heating operation, from being liquefied. This does not imply a problem.

13. Information on rating plate

PQHY-P-Y(S)HM-A

Model	PQHY-P200YHM-A(-BS)	PQHY-P250YHM-A(-BS)	PQHY-P300YHM-A(-BS)	PQHY-P400YSHM-A(-BS)		PQHY-P450YSHM-A(-BS)	
Unit combination	-	-	-	P200	P200	P250	P200
Refrigerant(R410A)	5.0kg	5.0kg	5.0kg	5.0kg	5.0kg	5.0kg	5.0kg
Allowable pressure(Ps)	HP:4.15MPa [601 psi], LP:2.21 MPa [320 psi]						
Net weight	195kg	195kg	195kg	195kg	195kg	195kg	195kg

Model	PQHY-P500YSHM-A(-BS)		PQHY-P550YSHM-A(-BS)		PQHY-P600YSHM-A(-BS)	
Unit combination	P250	P250	P300	P250	P300	P300
Refrigerant(R410A)	5.0kg	5.0kg	5.0kg	5.0kg	5.0kg	5.0kg
Allowable pressure(Ps)	HP:4.15MPa [601 psi], LP:2.21 MPa [320 psi]					
Net weight	195kg	195kg	195kg	195kg	195kg	195kg

PQRY-P-Y(S)HM-A

Model	PQRY-P200YHM-A(-BS)	PQRY-P250YHM-A(-BS)	PQRY-P300YHM-A(-BS)	PQRY-P400YSHM-A(-BS)		PQRY-P450YSHM-A(-BS)	
Unit combination	-	-	-	P200	P200	P250	P200
Refrigerant(R410A)	5.0kg	5.0kg	5.0kg	5.0kg	5.0kg	5.0kg	5.0kg
Allowable pressure(Ps)	HP:4.15MPa [601 psi], LP:2.21 MPa [320 psi]						
Net weight	181kg	181kg	181kg	181kg	181kg	181kg	181kg

Model	PQRY-P500YSHM-A(-BS)		PQRY-P550YSHM-A(-BS)		PQRY-P600YSHM-A(-BS)	
Unit combination	P250	P250	P300	P250	P300	P300
Refrigerant(R410A)	5.0kg	5.0kg	5.0kg	5.0kg	5.0kg	5.0kg
Allowable pressure(Ps)	HP:4.15MPa [601 psi], LP:2.21 MPa [320 psi]					
Net weight	181kg	181kg	181kg	181kg	181kg	181kg

This product is designed and intended for use in the residential, commercial and light-industrial environment.

The product at hand is based on the following EU regulations:

- Low Voltage Directive 2006/95/EC
- Electromagnetic Compatibility Directive 2004/108/EC
- Pressure Equipment Directive 97/23/EC

Please be sure to put the contact address/telephone number on this manual before handing it to the customer.

 **MITSUBISHI ELECTRIC CORPORATION**

HEAD OFFICE: TOKYO BLDG., 2-7-3, MARUNOUCHI, CHIYODA-KU, TOKYO 100-8310, JAPAN

Authorized representative in EU: MITSUBISHI ELECTRIC EUROPE B.V.

HARMAN HOUSE, 1 GEORGE STREET, UXBRIDGE, MIDDLESEX UB8 1QQ, U.K.